



RX200, RX300, RX400P and RX400DC



Installation Guide



Building Block Video Ltd.
17 Apex Park,
Diplocks Industrial Estate,
Hailsham, East Sussex, BN27 3JU UK.
Tel: +44(0)1323 842727
Fax: +44(0)1323 842728
Support: +44(0)1323 444600
www.bbvctv.com

IMPORTANT

Please read the following points
before servicing or installing any telemetry receiver.

Pre-installation Checks - It is recommended that the unit be bench-tested prior to installation on the site.

Safety During Installation or Servicing - Particular care should be taken to isolate the pan/tilt head in order to prevent operation while engineering work is being carried out. In addition any ladder or other means of working on the receiver MUST NOT rest on the pan/tilt head as it is possible for the head to move when not expected.

Safety Check - Upon completion of any service or repairs to the unit, safety checks should be performed to ensure that the unit is in proper operating condition.

Co-ax Grounding - If an outside cable system is connected to the unit, be sure the cable system is grounded.

Adhere to Safety Standards - All normal safety precautions as laid down by British Standards and the Health and Safety at Work Act should be observed.

WARNING - TO PREVENT DANGER OF FIRE OR SHOCK, DO NOT EXPOSE THE INTERNAL COMPONENTS OF THIS EQUIPMENT TO RAIN OR MOISTURE.

Damage Requiring Service - Servicing by qualified personnel should be carried out under the following conditions:

- (a) When the power-supply cord or plug is damaged;
- (b) If liquid has been spilled, or objects have fallen into, the unit;
- (c) If the internal electronics of the unit have been exposed to rain or water;
- (d) If the unit does not operate normally by following the operating instructions. Adjust only those controls that are covered by the operating instructions, as improper adjustment of other controls may result in damage and will often require extensive work by a qualified technician to restore the unit to normal operation;
- (e) If the unit has been dropped or the enclosure is damaged;
- (f) If the unit exhibits a distinct change in performance. This indicates a need for service.

Replacement Parts - If replacement parts are required, ensure that only replacement parts recommended by the product manufacturer are used.

Rx200 mk2

AC Left/Right/Wipe/Lights/Wash or Autopan, software Random Pan

UNPACKING

Inspect the packaging for signs of damage. If damage has occurred, advise the carriers and or the suppliers immediately. Unpack the receiver carefully and check that all the items are present and correct.

SAFETY PRECAUTIONS

All normal safety precautions as laid down by British Standards and the Health and Safety at Work Act should be observed and servicing should be referred to qualified service personnel.

Rx200 TECHNICAL SPECIFICATION

Power Requirements: 230 volts 50/60Hz (options are available for 24Vac and 110Vac supply)
IEC connector provided (screw terminals with 24Vac supply option)

Maximum Load: 5 amp at 230 volts

Receiver Current Draw: 6VA maximum

Fuse: Transformer contains a none resetting thermal fuse in series with the primary windings. If the transformer overheats, the fuse will protect the unit by going open circuit, removing power from the transformer.

F2: Auxiliary output fuse

Supply	Output	Fuse F2
230	230	5A T
230	24	315mA T
110	110	5A T
110	24	630mA T
24	24	5A T

Outputs: 5 single-pole changeover relays (snubbed):
1. LEFT PAN MOTOR
2. RIGHT PAN MOTOR
3. WIPER
4. WASHER OR AUTOPAN (switch selectable)
5. LIGHTS

Facilities/Options: Unit auto-tunes to the coaxial telemetry signal
LED readout for continual system status
Diagnostic test button (SW8) activates each function for two seconds in turn; see Table for test sequences
Video launch amplifier provided with Gain and Lift controls
Camera power outlet provided
Colour-coded outlets: Live, Neutral and Earth
24-volt output option available from factory; plugs into J5 (pre wired)
Software Random Pan – doesn't require autopan card in head.

Telemetry Signals: (a) Up the co-ax telemetry signals, designed to operate over 250M of RG59/500M CT125 co-ax; or (b) Twisted-pair 20mA loop (1200,E,8,1)

Auto-Iris Output: Returns to original setting 15 seconds after key release.
Level programmable from keypad.
To drive override input for cosmicar, or seiko style lens

Video Input: 1v p-p 75R Terminated Input via BNC socket

VideoOutput: 1v p-p to 4v p-p 75R Impedance via BNC socket

PCB Size: Width: 108 mm overall **Boxed size:** Width: 190mm
Length: 203 mm without IEC inserted Length: 380mm
Height: 38 mm above PCB Height: 130mm

PCB Weight: 0.4 kg **Boxed Weight:** 2.5kg

WAGO CONNECTERS

The WAGO series 256 PCB terminal block is a simple-to-use method of attaching cables to PCBs quickly and easily. The correct method of attachment is as follows:

1. Use only cable between 0.08 and 2.5 mm²
2. Strip the cable to a length of 5 to 6 mm (0.23 in)
3. Press down the relevant terminal block lever with a screwdriver
4. Insert wire
5. Remove screwdriver

Detachment of wires is the reverse procedure of steps 3 to 5, ensuring that **power is disconnected** before starting

CABLING RECOMMENDATIONS FOR RX RANGE OF RECEIVERS

Although BBV do not specify any particular type, manufacturer or supplier of cables, the following ESD Electronic Services (01279 626777) cables have been used successfully for production and testing:

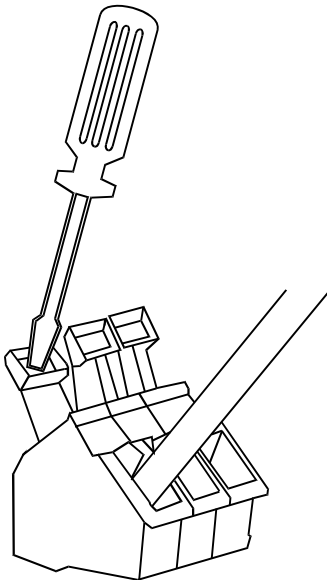

ESD Part Number:

Description:

071775G
(100 m)

Output Cable

18-core 16/0.2mm PVC insulated/PVC sheathed cable
Rated at 440 volts AC rms at 1600 Hz
DEF 61-12 current rating per core 2.5 amp
Maximum operating temperature: 70 degrees Celsius

0222586G
(100 m)

Co-Ax Cable (Minimum Specification)

RG59B/U ESD radio frequency co-ax cable to BS2316 and MIL-C-17
1/0.58mm copper-covered steel wire conductor with solid polythene dielectric,
bare copper wire braid and PVC sheath
Characteristic impedance: 75 Ohm
Capacitance: 22pF/ft

020966D
(100 m)

Orange Coloured Lights Output Cable (1000 w)

3183Y PVC Insulated 3 core cable
1.25mm² 40/0.2mm annealed copper conductor
Current rating: 13 amp

0140467H
(100 m)

20mA Twisted Pair Cable (Minimum Specification)

British Telecom Spec. CW 1308
2-core 1/0.5mm PVC insulated
Maximum conductor resistance at 20 degrees Celsius: 97.8 ohms/Km

Rx200 INSTALLATION INSTRUCTIONS

The Rx200 requires all connections to the PCB to be made by the installer and via terminal blocks or by plug and socket. These connections are: power, video in, video out, and pan or auxiliary outputs. See Table for the correct connections.

The Rx200 is normally supplied pre-configured to suit the application for which it is intended, and this will be either to control a mains-operated panning head or other equipment, or to control a 24-volt panning head. The unit is suitable for **230 volt** mains operation. As a factory fitted option, the receiver can be supplied to operate from 24Vac or 110Vac. This option must be specified at time of order.

For mains-voltage panning heads, the **110Vac or 230Vac** supply is made via the IEC socket J4 .
(Note - for mains operations, J5 is supplied with a header which links Pins 1 to 4 and Pins 3 to 6.)

When using 24Vac heads, if the receiver is operating from a 110Vac or 230Vac supply either a 230/24Vac Kit or 110/24Vac Kit is used. The jumper fitted to J5 is removed and the plug supplied with the kit is connected to J5. Fuse F2 is changed to the value shown in the table on 2.

Receivers operating from 24Vac can only operate 24Vac heads. No kit is required.

When operating from a 24Vac supply, power connection is by means of a screw terminal replacing the IEC socket.

An 8 way DIL switch is provided allowing various options to be set as follows:-

SW1	Unused
SW2	Controls auto-iris remote control features
	ON Cosmicar lens, 2.5 - 5.5 volts
	OFF Seiko/Video Technical lens, 2.5 - 12 volts
SW3 and SW4	Select between WASHER or AUTOPAN
	<u>SW3</u> <u>SW4</u> <u>Function</u>
	ON ON WASHER
	OFF OFF AUTOPAN
SW5,6,7	Unused
SW8	Start receiver self test, see page 5.

Two L.E.D.'s (Error and Cable) are mounted on-board to give simple system status information. Their functions are as follows:-

Cable LED

Regular Blinking - Telemetry and Sync signals OK

Blinking but mainly ON - No telemetry information from the transmitter

Blinking but mainly OFF - No sync information from the camera

Error LED

On - Transmission error (e.g. framing error, parity error)

Both LED's

Off - No power, or major PCB error

As all BBV equipment is designed to auto-tune and compensate for any discrepancies in the transmitter signal, there are no further adjustments that need to be made.

Random Pan

The Random Pan feature allows the receiver to drive the head in a left or right direction at random for a random time. The head will pause for a random time between movements. Over a period of time, the head will move between the right and left end stops. This feature does not require an autopan card to be fitted to the head. The Random Pan is started by issuing a PATROL 1 command from the telemetry controller. The key strokes required will vary depending upon the model of controller. Please refer to the controller handbook for details.

LAUNCH AMPLIFIER

There are two variable controls, Lift and Gain, situated close to the BNC connector J1. These are pre-adjusted for a cable distance of 250M, and are adjustable to compensate for video detail or signal losses if and when longer or shorter cable lengths are used to connect the monitor to the receiver.

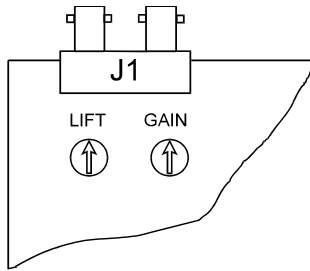

Default Position. For shorter cable lengths, turn the relevant control anti-clockwise until the required picture quality is obtained. For longer cable lengths, turn the relevant control clockwise until the required picture clarity is obtained.

The purpose of each control is:

Lift: boosts the high-frequency signal

Gain: adjusts the gain of the video signal

ATTENTION: Ensure that the cable is terminated at the monitor end **ONLY**.

CABLE CONNECTIONS FOR Rx200 UNITS

Colour	Function	Connection
Main Cable		
Brown	Camera Power Live	J6-12
Green	Camera Power Ground	J6-11
Blue	Camera Power Neutral	J6-10
Red	PAN LEFT (SWITCHED OUTPUT)	J6-9
Yellow	PAN RIGHT (SWITCHED OUTPUT)	J6-8
Black	WASH/AUTOPAN(SWITCHED OUTPUT)	J6-7
White	WIPER (SWITCHED OUTPUT)	J6-6
Green/Red	EARTH	J6-5
Turquoise	NEUTRAL	J6-4
Red/Blue	LIGHTS LIVE (SWITCHED OUTPUT)	J6-3
Yellow/Red	LIGHTS EARTH	J6-2
White/Red	LIGHTS NEUTRAL	J6-1
	Auto Iris Override Ground	J3-4
Violet	Auto Iris Override	J3-3
Separate Cable	20 mA Twisted Pair Connection	J3-2
Separate Cable	20 mA Twisted Pair Connection	J3-1

Rx300 mk2

AC Pan/Tilt/Zoom/Focus/1 Aux software Random Pan

UNPACKING

Inspect the packaging for signs of damage. If damage has occurred, advise the carriers and or the suppliers immediately. Unpack the receiver carefully and check that all the items are present and correct.

SAFETY PRECAUTIONS

All normal safety precautions as laid down by British Standards and the Health and Safety at Work Act should be observed and servicing should be referred to qualified service personnel.

Rx300 TECHNICAL SPECIFICATION

Power Requirements: 230 volts 50/60Hz (options are available for 24Vac and 110Vac supply)
IEC connector provided (screw terminals with 24Vac supply option)

Maximum Load: 5 amp at 230 volts

Receiver Current: 6VA maximum

Fuse: Transformer contains a none resetting thermal fuse in series with the primary windings. If the transformer overheats, the fuse will protect the unit by going open circuit, removing power from the transformer.

F2: Auxiliary output fuse

Supply	Output	Fuse F2
230	230	5A T
230	24	315mA T
110	110	5A T
110	24	630mA T
24	24	5A T

Outputs: 5 single-pole changeover relays (snubbed):

1. Left motor
2. Right motor
3. Up motor
4. Down motor
5. A single auxiliary output

Auxiliary output selectable as **one** of following:

- a. Wash
- b. Wipe
- c. Lights (maximum 1000 watt load)
- d. Autopan, if selected, interlocks with pan left/right.

Facilities/Options: Unit auto-tunes to the coaxial telemetry signal
LED readout for continual system status
Diagnostic test button (SW8) activates each function for two seconds in turn;
see the table for test sequences
Video launch amplifier provided with Gain and Lift controls
Camera power outlet provided
Colour-coded outlets: Live, Neutral and Earth
24-volt output option available from factory; plugs into J5 (pre wired)
Software Random Pan – doesn't require autopan card in head.

Telemetry Signals: (a) Up the co-ax telemetry signals, designed to operate over 250M of RG59/500M CT125 co-ax; or (b) Twisted-pair 20mA loop (1200,E,8,1)

Auto-Iris Output: Returns to original setting 15 seconds after key release.
Level programmable from keypad
To drive override input for cosmicar, or seiko style lens

Video Input: 1v p-p 75R Terminated Input via BNC socket

VideoOutput: 1v p-p to 4v p-p 75R Impedance via BNC socket

PCB Size: Width: 108 mm overall **Boxed size:** Width: 190mm
Length: 203 mm without IEC inserted Length: 380mm
Height: 38 mm above PCB Height: 130mm

PCB Weight: 0.4 kg **Boxed Weight:** 2.5kg

WAGO CONNECTERS

The WAGO series 256 PCB terminal block is a simple-to-use method of attaching cables to PCBs quickly and easily. The correct method of attachment is as follows:

1. Use only cable between 0.08 and 2.5 mm²
2. Strip the cable to a length of 5 to 6 mm (0.23 in)
3. Press down the relevant terminal block lever with a screwdriver
4. Insert wire
5. Remove screwdriver

Detachment of wires is the reverse procedure of steps 3 to 5, ensuring that **power is disconnected** before starting

CABLING RECOMMENDATIONS FOR RX RANGE OF RECEIVERS

Although BBV do not specify any particular type, manufacturer or supplier of cables, the following ESD Electronic Services (01279 626777) cables have been used successfully for production and testing:

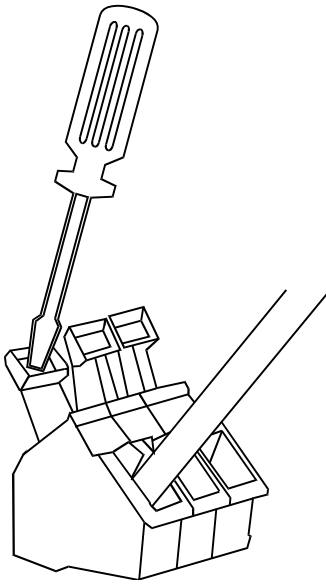

ESD Part Number:

Description:

071775G
(100 m)

Output Cable

18-core 16/0.2mm PVC insulated/PVC sheathed cable
Rated at 440 volts AC rms at 1600 Hz
DEF 61-12 current rating per core 2.5 amp
Maximum operating temperature: 70 degrees Celsius

0222586G
(100 m)

Co-Ax Cable (Minimum Specification)

RG59B/U ESD radio frequency co-ax cable to BS2316 and MIL-C-17
1/0.58mm copper-covered steel wire conductor with solid polythene dielectric,
bare copper wire braid and PVC sheath
Characteristic impedance: 75 Ohm
Capacitance: 22pF/ft

020966D
(100 m)

Orange Coloured Lights Output Cable (1000 w)

3183Y PVC Insulated 3 core cable
1.25mm² 40/0.2mm annealed copper conductor
Current rating: 13 amp

0140467H
(100 m)

20mA Twisted Pair Cable (Minimum Specification)

British Telecom Spec. CW 1308
2-core 1/0.5mm PVC insulated
Maximum conductor resistance at 20 degrees Celsius: 97.8 ohms/Km

Rx300 INSTALLATION INSTRUCTIONS

The Rx300 requires all connections to the PCB to be made by the installer and via terminal blocks or by plug and socket. These connections are: power, video in, video out, and pan or auxiliary outputs. See Table for the correct connections.

The Rx300 is normally supplied pre-configured to suit the application for which it is intended, and this will be either to control a mains-operated panning head or other equipment, or to control a 24-volt panning head. The unit is suitable for **230 volt** mains operation. As a factory fitted option, the receiver can be supplied to operate from 24Vac or 110Vac. This option must be specified at time of order.

For mains-voltage panning heads, the **110Vac or 230Vac** supply is made via the IEC socket J4 .
(Note - for mains operations, J5 is linked Pins 1 to 4 and Pins 3 to 6.)

When using 24Vac heads, if the receiver is operating from a 110Vac or 230Vac supply either a 230/24Vac Kit or 110/24Vac Kit is used. The jumper fitted to J5 is removed and the plug supplied with the kit is connected to J5. Fuse F2 is changed to the value shown in the table on 2.

Receivers operating from 24Vac can only operate 24Vac heads. No kit is required.

When operating from a 24Vac supply, power connection is by means of a screw terminal replacing the IEC socket.

An 8 way DIL switch is provided allowing various options to be set as follows:-

SW1	On - 6 volt lens-motor drive Off - 12 volt lens-motor drive															
SW2	Controls auto-iris remote control features On - Cosmocar lens, 2.5 - 5.5 volts Off - Seiko/Video Technical lens, 2.5 - 12 volts															
SW3 and SW4	Select auxiliary function (single function only)															
	<table><thead><tr><th><u>SW3</u></th><th><u>SW4</u></th><th><u>Function</u></th></tr></thead><tbody><tr><td>On</td><td>On</td><td>Wash</td></tr><tr><td>On</td><td>Off</td><td>Lights</td></tr><tr><td>Off</td><td>On</td><td>Wipe</td></tr><tr><td>Off</td><td>Off</td><td>Autopan</td></tr></tbody></table>	<u>SW3</u>	<u>SW4</u>	<u>Function</u>	On	On	Wash	On	Off	Lights	Off	On	Wipe	Off	Off	Autopan
<u>SW3</u>	<u>SW4</u>	<u>Function</u>														
On	On	Wash														
On	Off	Lights														
Off	On	Wipe														
Off	Off	Autopan														
SW5	On - Overrides Random Pan (Patrol 1)															
SW6	Not Used															
SW7	on - Overrides Remote Self Test															
SW8	Start receiver self test, see later in manual.															

Two L.E.D.'s (Error and Cable) are mounted on-board to give simple system status information. Their functions are as follows:-

Cable LED

Regular Blinking - Telemetry and Sync signals OK

Blinking but mainly ON - No telemetry information from the transmitter

Blinking but mainly OFF - No sync information from the camera

Error LED

On - Transmission error (e.g. framing error, parity error)

Both LED's

Off - No power, or major PCB error

As all BBV equipment is designed to auto-tune and compensate for any discrepancies in the transmitter signal, there are no further adjustments that need to be made.

Random Pan

The Random Pan feature allows the receiver to drive the head in a left or right direction at random for a random time. The head will pause for a random time between movements. Over a period of time, the head will move between the right and left end stops. This feature does not require an autopan card to be fitted to the head. The Random Pan is started by issuing a PATROL 1 command from the telemetry controller. The key strokes required will vary depending upon the model of controller. Please refer to the controller handbook for details.

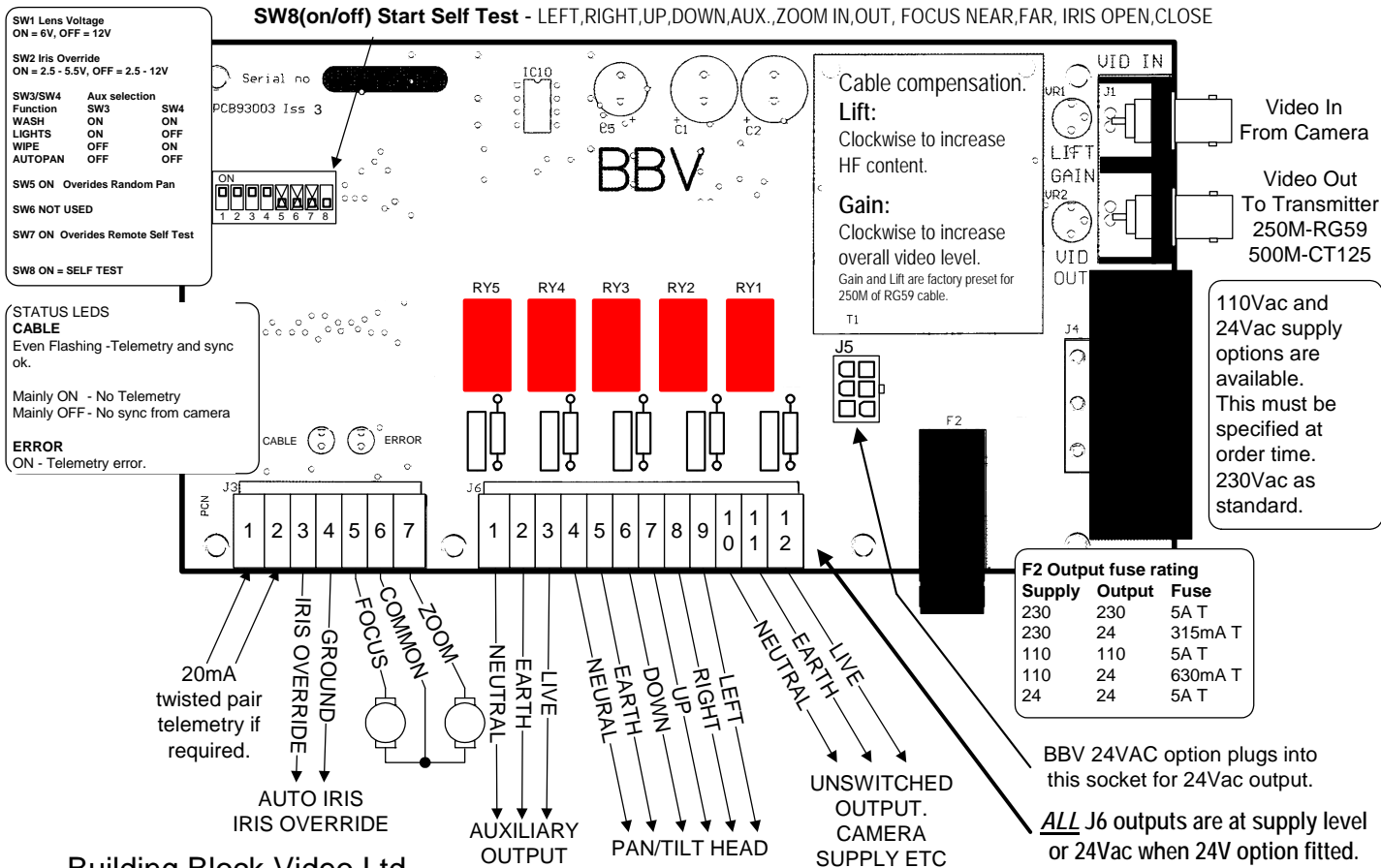

Rx300 Mark II Connections

SELF-TEST AND DIAGNOSTIC SEQUENCES

The diagnostic system and status check, which will activate each camera function for two seconds in turn, is activated either locally by pressing a switch on the PCB or remotely from a BBV keypad. When testing the system locally, before initiating the diagnostic system and status check by turning SW8 ON momentarily, ensure that the Cable LED is on (i.e. either flashing or continuously). If not, this indicates that either the power is not attached to the PCB, or there has been a major PCB error. Rectify accordingly.

The Error LED flashes at a two-second rate during self-test. If the Cable LED fails to extinguish, then the unit is unable to self-tune and should be returned for repair.

Order of function test:	Camera Moves Left
	Camera Moves Right
	Camera Moves Up
	Camera Moves Down
	Auxiliary Function
	Lens Zoom-In
	Lens Zoom-Out
	Lens Focus Near
	Lens Focus Far
	Auto Iris Open
	Auto Iris Close
	Diagnostic Check Complete, unit resets and continues normal operation.

LAUNCH AMPLIFIER

There are two variable controls, Lift and Gain, situated close to the BNC connector J1. These are pre-adjusted for a cable distance of 250M, and are adjustable to compensate for video detail or signal losses if and when longer or shorter cable lengths are used to connect the monitor to the receiver.

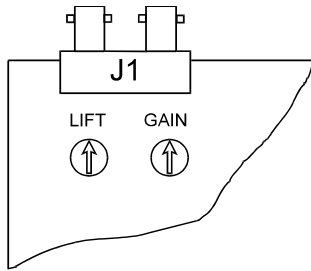

Default Position. For shorter cable lengths, turn the relevant control anti-clockwise until the required picture quality is obtained. For longer cable lengths, turn the relevant control clockwise until the required picture clarity is obtained.

The purpose of each control is:

Lift: boosts the high-frequency signal

Gain: adjusts the gain of the video signal

ATTENTION: Ensure that the cable is terminated at the monitor end **ONLY**

CABLE CONNECTIONS FOR Rx300 UNITS

Colour	Function	Connection
Main Cable (18 Core)		
Brown	Camera Power Live	J6-12
Green	Camera Power Ground	J6-11
Blue	Camera Power Neutral	J6-10
Red	Pan Left	J6-9
Yellow	Pan Right	J6-8
Black	Tilt Up	J6-7
White	Tilt Down	J6-6
Green/Red	Motor Head Earth	J6-5
Turquoise	Motor Head Return	J6-4
Red/Blue	Auxiliary Function Autopan	J6-3 **
Red/Brown	Auxiliary Function Wash Live	J6-3 **
Red /Black	Auxiliary Function Wipe Live	J6-3 **
Yellow/Red	Auxiliary Function Earth	J6-2
White/Red	Auxiliary Function Neutral	J6-1
Orange	Lens Drive Zoom Motor	J3-7
Grey	Lens Drive Motor Return (Ground)	J3-6
Pink	Lens Drive Focus Motor	J3-5
	Auto Iris Override Ground	J3-4
Violet	Auto Iris Override	J3-3
Separate Cable	20 mA Twisted Pair Connection	J3-2
Separate Cable	20 mA Twisted Pair Connection	J3-1
Lighting Cable (Orange 3-Core)		
Brown	Auxiliary Function Lights Live	J6-3 **
Green/Yellow	Auxiliary Function Earth	J6-2
Blue	Auxiliary Function Neutral	J6-1

Depending on the jumper selection of SW3 and SW4, only **one of the four auxiliary functions can be selected at any one time.

Rx400P mk2 AC Pan/Tilt/Zoom/Focus/Iris/4 Aux 16 preset positions

For details of the revised ISSUE 5 PCB please refer to page 18.

UNPACKING

Inspect the packaging for signs of damage. If damage has occurred, advise the carriers and/or the suppliers immediately. Unpack the receiver carefully and check that all the items are present and correct.

SAFETY PRECAUTIONS

All normal safety precautions as laid down by British Standards and the Health and Safety at Work Act should be observed and servicing should be referred to qualified service personnel.

Rx400P TECHNICAL SPECIFICATION

Power Requirements: 230Vac 50/60Hz (options are available for 24Vac and 110Vac supply)
IEC connector provided (screw terminals with 24Vac supply option)

Maximum Load: 5 amp at 230 volts

Receiver Current: 6VA maximum

Fuse: Transformer contains a none resetting thermal fuse in series with the primary windings. If the transformer overheats, the fuse will protect the unit by going open circuit, removing power from the transformer.

F2: Auxiliary output fuse

Supply	Output	Fuse F2
230	230	5A T
230	24	315mA T
110	110	5A T
110	24	630mA T
24	24	5A T

Outputs: 8 single-pole changeover relays (snubbed)
1. Left motor
2. Right motor
3. Up motor
4. Down motor
5. Autopan (interlocked with pan left/right)
6. Lights (1000W maximum)
7. Wash
8. Wipe

Facilities/Options: Unit auto-tunes to the coaxial telemetry signal
LED readout for continual system status
Diagnostic test switch (SW8) activates each function for two seconds in turn.
See the table for test sequences
Video launch amplifier provided with Gain and Lift controls
Camera power outlet provided.
Colour-coded outlets: Live, Neutral and Earth.
24-volt option available from factory; plugs into J5 (pre wired)

Telemetry Signals: (a) Up the co-ax telemetry signals, designed to operate over 250M of RG59/500M of CT125 co-ax; or (b) Twisted pair 20mA loop (1200,E,8,1)

Auto-Iris Output: Returns to original setting 15 seconds after key release
Level is programmable from keypad
Will drive the override input for Cosmocar or Seiko-style lens

Video Input: 1v p-p 75R terminated input via BNC socket

Video Output: 1v p-p to 4v p-p 75R impedance via BNC socket

Lens Drive: Adjustable via control VR4 /LENS, and ranges between 3 and 12 volts
Inching speed adjustable control VR3/INCH between 0% and 100% of full lens voltage One-second inching built in
Drives provided for **Zoom**, **Focus** and **Motorised Iris**.
Each lens drive carries a bi-colour LED to indicate correct lens drive function

Presets: Inputs are provided for preset feedback pots.
These inputs are: 10-bit resolution, pan, tilt, zoom and focus. Up to 16 preset positions can be stored within the Rx. Each position consists of a complete view, i.e. pan, tilt, zoom and focus settings

Other Outputs: The lights-relay output is mimicked on auxiliary output 1 (J9-2).
See installation instructions for further details.
Spare relay-drive outputs are available

PCB Size: Width: 108 mm overall
Length: 242 mm without IEC inserted
Height: 38 mm above PCB

PCB Weight: 0.5 kg

Boxed Size Width: 190 mm
Length: 380 mm
Height: 130 mm

Boxed Weight: 2.5 kg

WAGO CONNECTERS

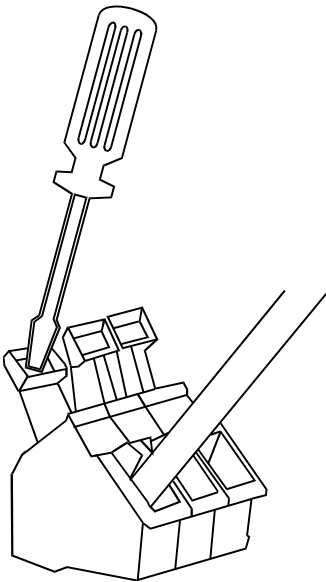

The WAGO series 256 PCB terminal block is a simple-to-use method of attaching cables to PCBs quickly and easily. The correct method of attachment is as follows:

1. Use only cable between 0.08 and 2.5 mm²
2. Strip the cable to a length of 5 to 6 mm (0.23 in)
3. Press down the relevant terminal block lever with a screwdriver
4. Insert wire
5. Remove screwdriver

Detachment of wires is the reverse procedure of steps 3 to 5, ensuring that **power is disconnected** before starting

CABLING RECOMMENDATIONS FOR Rx RANGE OF RECEIVERS

Although BBV do not specify any particular type, manufacturer or supplier of cables, the following ESD Electronic Services (01279 626777) cables have been used successfully for production and testing:

ESD Part Number:	Description:
071775G (100 m)	Output Cable 18-core 16/0.2mm PVC-insulated/PVC-sheathed cable Rated at 440 volts AC rms at 1600 Hz DEF 61-12 current rating per core 2.5 amp Maximum operating temperature: 70 degrees Celsius
038309R (100 m)	Preset Cable 8-core 7/0.2mm PVC-insulated, overall braid screened Rated at 440 volts AC rms at 1600 Hz DEF 61-12 current rating per core 1.0 amp Maximum operating temperature: 70 degrees Celsius

0222586G
(100 m)

Co-Ax Cable (Minimum Specification)

RG59B/U ESD radio frequency co-ax cable to BS2316 and MIL-C-17
1/0.58mm copper-covered steel wire conductor with solid polythene dielectric,
bare copper wire braid and PVC sheath
Characteristic impedance: 75 Ohm
Capacitance: 22pF/ft

020966D
(100 m)

Orange-Coloured Lights Output Cable (1000 w)

3183Y PVC-insulated, 3-core cable
1.25mm² 40/0.2mm annealed copper conductor
Current rating: 13 amp

0140467H
(100 m)

20mA Twisted Pair Cable (Minimum Specification)

British Telecom spec CW 1308
2-core 1/0.5mm PVC-insulated
Maximum conductor resistance at 20 degrees Celsius: 97.8 ohms/km

LAUNCH AMPLIFIER

There are two variable controls, Lift and Gain, situated close to the BNC connector J1. These are pre-adjusted for a cable distance of 250M, and are adjustable to compensate for video detail or signal losses if and when longer or shorter cable lengths are used to connect the monitor to the receiver.

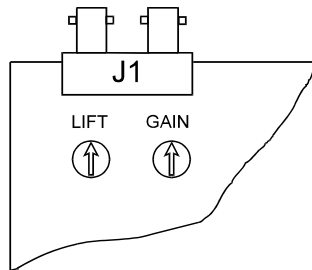

Default Position. For shorter cable lengths, turn the relevant control anti-clockwise until the required picture quality is obtained. For longer cable lengths, turn the relevant control clockwise until the required picture clarity is obtained.

The purpose of each control is:

Lift: boosts the high-frequency signal

Gain: adjusts the gain of the video signal

ATTENTION: Ensure that the cable is terminated at the monitor end **ONLY**

PRESETS ON THE Rx400P

When using presets ensure correct connection of the feedback pots. Pay particular attention to ensuring that power is not connected across one end of the pot and the wiper, as damage to the feedback pot may ensue.

Beyond connecting the correct wiper to each function input, i.e. focus wiper to focus input etc. , the installer does not need to worry about reversing the polarity/direction of travel. If for instance the pan/tilt head has been installed upside down, the receiver will compensate for this arrangement.

Before using presets it is necessary to use the self test function, turn SW8 ON momentarily. During the course of the self test the receiver senses the feedback pot connections. If the cabling/travel is reversed then the unit will reset the relevant direction bits within the receiver. Subsequent searches to preset should now function correctly.

**DO NOT PROGRAM PRESETS CLOSE
TO PHYSICAL ENDSTOPS**

Rx400P INSTALLATION INSTRUCTIONS

The Rx400P requires all connections to the PCB to be made by the installer, and via terminal blocks or by plug and socket. These connections are: power, video in, video out, and pan or auxiliary outputs. See Table for the correct connections.

The Rx400P is normally supplied pre-configured to suit the application for which it is intended, and this will be either to control a mains-operated panning head or other equipment, or to control a 24-volt panning head. The unit is suitable for **230 volt** mains operation. As a factory fitted option, the receiver can be supplied to operate from 24Vac or 110Vac. This option must be specified at time of order.

For mains-voltage panning heads, the **110Vac or 230Vac** supply is made via the IEC socket J4 . (Note - for mains operations, J5 is linked Pins 1 to 4 and Pins 3 to 6.)

When using 24Vac heads, if the receiver is operating from a 110Vac or 230Vac supply either a 230/24Vac Kit or 110/24Vac Kit is used. The jumper fitted to J5 is removed and the plug supplied with the kit is connected to J5. Fuse F2 is changed to the value shown in the table on 2.

Receivers operating from 24Vac can only operate 24Vac heads. No kit is required.

When operating from a 24Vac supply, power connection is by means of a screw terminal replacing the IEC socket.

An 8 way DIL switch is provided allowing various options to be set as follows:-

SW1 Controls auto-iris remote control features (See Appendix for Lens List)

ON Cosmicar lens 2.5 - 5.5 volts
OFF Seiko/Video Technical lens 2.5 - 12 volts

SW2 Reverses focus motor direction

SW3 Reverses zoom motor direction

SW4 Reverses iris motor direction

SW5,6,7 **Unused – see page xx for new issue 5 pcb details**

SW8 **Start receiver self test, see later in manual.**

Two L.E.Ds (Error and Cable) are mounted on-board to give simple system status information. Their functions are as follows:

Cable LED

Regular blinking - Telemetry and sync signals OK
Blinking but mainly ON - No telemetry information from the transmitter
Blinking but mainly OFF - No sync information from the camera

Error LED

On - Transmission error (e.g. framing error, parity error)

Both LEDs

Off - No power or major PCB error

As all BBV equipment is designed to auto-tune and compensate for any discrepancies in the transmitter signal, there are no further adjustment that need to be made

SW8(on/off) Start Self Test - LEFT,RIGHT,UP,DOWN,AUTOPAN,LAMPS,WIPE,WASH,ZOOM IN,OUT, FOCUS NEAR,FAR, IRIS OPEN,CLOSE

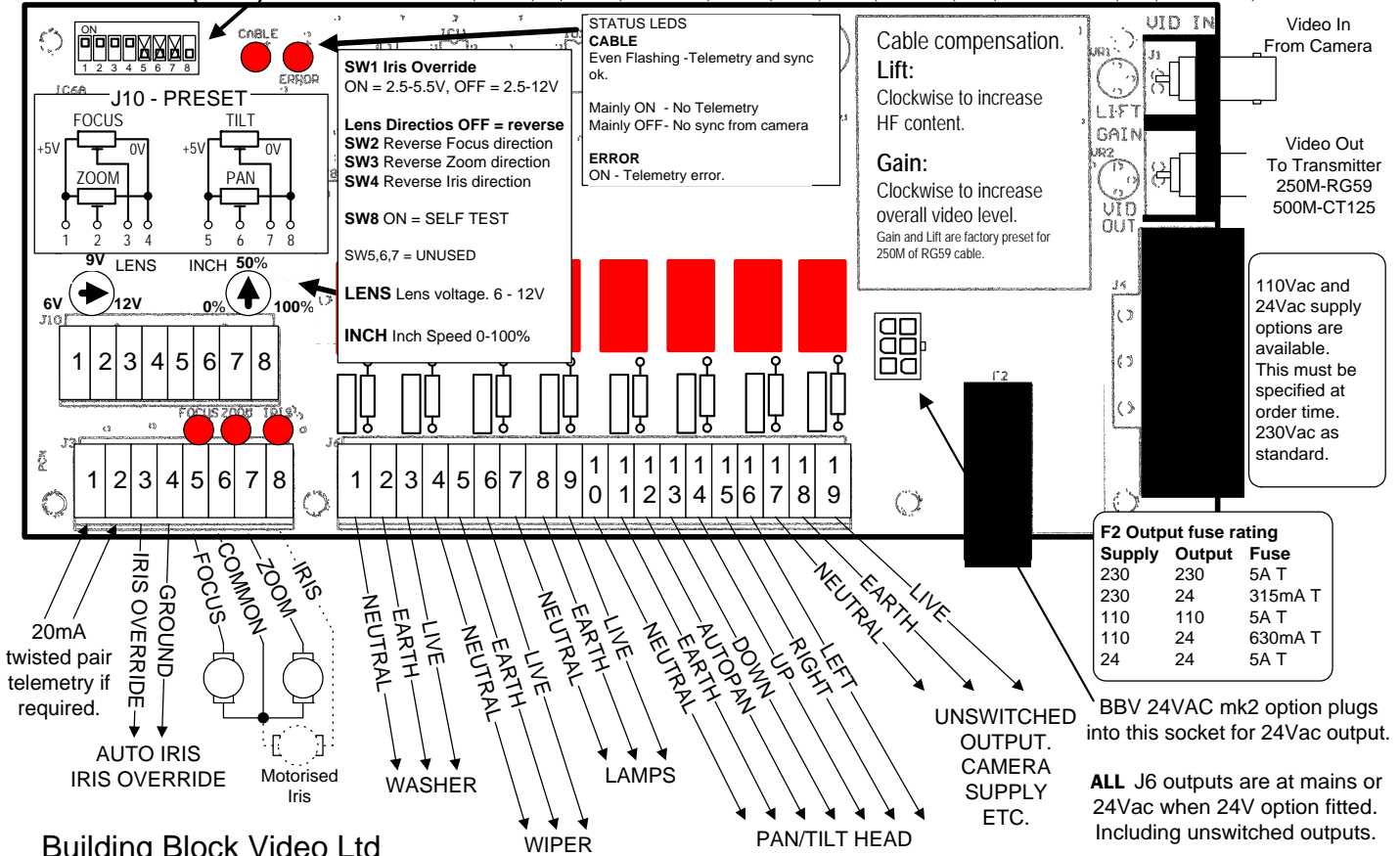

Building Block Video Ltd

17 Apex Park, Diplocks Industrial Estate, Hailsham, East Sussex, UK. BN27 3JF. Tel: +44 (0)1323 842727 Fax: +44 (0)1323 842728
 Tech Support: +44 (0)1323 444600 Web site for manuals/data sheets/application notes etc. www.bbvcctv.com

Rx400P Mark II Connections

SELF-TEST AND DIAGNOSTIC SEQUENCES

The diagnostic system-and-status check, which will activate each camera function for two seconds in turn, is activated either locally by pressing a switch on the PCB, or remotely from a BBV keypad. When testing the system locally, before initiating the diagnostic system-and-status check by momentarily turning SW8 ON, ensure that the Cable LED is **on** (i.e. either flashing or continuously). If not, this indicates that either the power is not connected to the PCB, or there has been a major PCB error. Rectify accordingly.

The Error LED flashes at a two-second rate during self-test. If the Cable LED fails to extinguish, then the unit is unable to self-tune and should be returned for repair.

Order of function test:

Camera moves left
Camera moves right
Camera moves up
Camera moves down
Autopan
Lights and auxiliary output J9-2 "on"
Wiper assembly
Washer assembly
Lens zoom in
Lens zoom out
Lens focus near
Lens focus far
Auto-iris open
Auto-iris close
Iris motor drive open
Iris motor drive close
Diagnostic check complete, unit resets and continues normal operation.

CABLE CONNECTIONS FOR Rx400P UNITS

Colour	Function	Connection
Main Cable (18-Core)		
Brown	Camera Power Live	J6-19
Green	Camera Power Ground	J6-18
Blue	Camera Power Neutral	J6-17
Red	Pan Left	J6-16
Yellow	Pan Right	J6-15
Black	Tilt Up	J6-14
White	Tilt Down	J6-13
Red/Blue	Autopan	J6-12
Green/Red	Motor Head Earth	J6-11
Turquoise	Motor Head Return	J6-10
Red /Black	Wipe Live	J6-6
Yellow/Red	Wipe Earth	J6-5
White/Red	Wipe Neutral	J6-4
Red/Brown	Wash Live	J6-3
Orange	Lens Drive Zoom Motor	J3-7
Grey	Lens Drive Motor Return (Gnd)	J3-6
Pink	Lens Drive Focus Motor	J3-5
	Auto Iris Override Ground	J3-4
Violet	Auto Iris Override	J3-3 (See A)
	20 mA Twisted Pair Connection	J3-2
	20 mA Twisted Pair Connection	J3-1
Lighting Cable (Orange 3-Core)		
Brown	Lights Live	J6-9
Green/Yellow	Lights Earth	J6-8
Blue	Lights Neutral	J6-7
Model 4P Presets Cable (8-Core)		
Blue	Head Preset Zero Volts	J10-8
Red	Head Preset Tilt	J10-7
Yellow	Head Preset Pan	J10-6
Purple	Head Preset +5 Volts	J10-5
Green + Screen	Lens Preset Zero Volts	J10-4
Black	Lens Preset Focus	J10-3
White	Lens Preset Zoom	J10-2
Brown	Lens Preset +5 Volts	J10-1

Note A:

When the fitted camera lens has a straight motorised iris, the Violet wire should be connected to J3-8, **not** J3-3

Amendment when using latest issue 5 of the Rx400P PCB.

This issue of PCB has differences from previous issues. The major difference being the mounting of all components onto the top side of the PCB and cosmetic differences with the position of the lens adjustment pots and the setting of the video gain pot.

In addition, the following new operating features are provided.

DISABLE REMOTE SELF TEST – SW5 (default off)

When used in electrically noisy environments and using up-the-coax telemetry that interference can cause the receiver to start a self test. In previous issues of PCB, a change of software was required. This generation allows remote self test to be disabled by setting SW5 ON. For normal operation SW5 should be OFF.

DISABLE LENS PRESET – SW6 (default off)

If the receiver is used with a lens without preset feedback, setting SW6 ON will prevent the lens from being driven during preset operation. This would generally only occur in electrically noisy environments.

DATUM OR “SELF PARK” MODE – SW7 (default off)

Setting SW7 ON will enable datum or “self park” operation. After a period of 2 minutes of pan/tilt inactivity the receiver will drive the head/lens to preset position 1. This is useful to allow a sensitive area to be viewed when the operator is not manually controlling the head. When SW7 is ON, then preset patrol is disabled. Should preset patrol be required then SW7 must be set to OFF. Previous issues of the PCB required bespoke software for this feature.

The following page shows the new pcb layout.

SW8(on/off) Start Self Test - LEFT,RIGHT,UP,DOWN,AUTOPAN,LAMPS,WIPE,WASH,ZOOM IN,OUT, FOCUS NEAR,FAR, IRIS OPEN,CLOSE

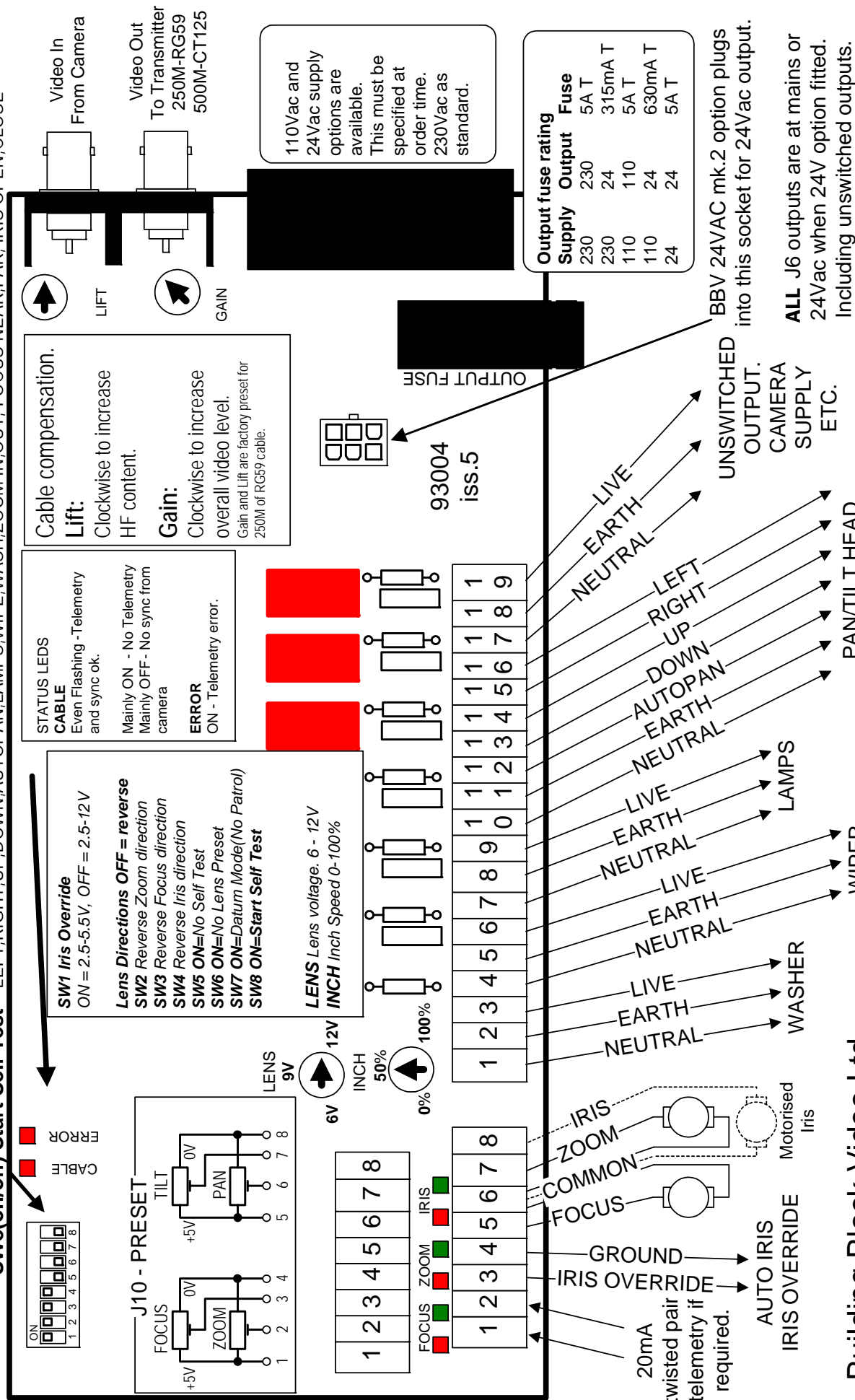

Rx400P Mark II Issue 5 Connections

Building Block Video Ltd

17 Apex Park, Hailsham, East Sussex, UK. BN27 3JF. Tel: +44 (0)1323 842727 Fax: +44 (0)1323 842728
 Tech Support: +44 (0)1323 444600 Web site for manuals/data sheets/application notes etc. www.bbvcctv.com

Rx400DC

24Vdc high/variable Pan/Tilt Zoom/Focus/Iris/3 Aux 16 presets
8 local alarms 12Vdc 500mA supply.

TABLE OF CONTENTS

1. Pre-installation Checks and Safety Procedures	22
Unpacking	22
Important safety precautions	22
2. Introduction	23
General	23
Technical specification	23, 24
Programmable output features	23
Cable connection method	25
<i>Fig. 1 Wago cable connectors</i>	
Cable types	25
3. Installation	26
Operating voltage	26
Cable connection instructions	27
<i>Fig. 2 Cable connection diagram</i>	
4. Setup	28
Diagnostic aids	28
Cable length compensation	29
<i>Fig. 3 Launch amplifier</i>	
Self-test	29
<i>Fig. 4 Self test sequence</i>	
Programming the unit	30, 31
Settings for normal operation	32
Patrol Mode and Datum operation	32
Pre-sets	33

1. PRE-INSTALLATION CHECKS AND SAFETY PROCEDURES

UNPACKING

Check Packaging - Upon taking delivery of the unit, inspect the packaging for signs of damage. If damage has occurred, advise the carriers and/or the suppliers immediately.

Check Contents - Upon taking delivery of the unit, unpack the receiver carefully and check that all the items are present and correct. If any items are missing or damaged, contact your equipment dealer.

Retain Packaging - The shipping carton is the safest container in which to transport the unit. Retain undamaged packaging for possible future use.

IMPORTANT SAFETY PRECAUTIONS

Read Instructions - All relevant safety, installation and operating instructions should be read before attempting to install, connect or operate the unit.

Retain Instructions - All safety, installation and operating instructions should be retained for future reference.

Heed Warnings - All warnings on the unit and in any relevant safety, installation or operating instructions should be adhered to.

Cleaning - Unplug the unit from the power outlet before cleaning. Do not use liquid cleaners or aerosol cleaners. Use a damp cloth for cleaning.

Attachments - Do not use attachments not recommended by the product manufacturer as they may cause hazards.

Water and Moisture - Do not expose the internal electronics of this unit to water or dampness; for example, in an unprotected outdoor installation, or in any area classified as a wet location. The unit as supplied conforms to ingress protection rating IP 65. This rating will be affected by any holes made in the enclosure. Cable entry points should be protected by the use of suitably rated glands and/or flexible conduit. It is not necessary to make further holes in the enclosure for mounting purposes, as mounting holes are provided at the corners of the enclosure outboard of the seal between enclosure and lid.

Accessories - Do not attach this unit to an unstable stand, bracket or mount. The unit may fall, causing serious injury to a person and serious damage to the unit.

Power Sources - This unit should be operated only from the type of power source indicated on the manufacturer's label. If you are not sure of the type of power supply you intend to use, consult your equipment dealer or local power company. For units intended to operate from battery power or other sources, refer to operating instructions.

Power Connector - This unit is equipped with an IEC female connector mounted at the edge of the PCB for mains power input. Do not attempt to alter this connector in any way.

Power Cord Protection - Power supply cords should be routed so that they are not likely to be trapped, pinched or otherwise damaged by items in close proximity to them, whether inside the unit or outside it. Particular attention should be paid to cords at plugs, connection units and the point of exit from the unit.

Overloading - Do not overload outlets and extension cords, as this can result in fire or electric shock.

Object and Liquid Entry - Never push objects of any kind into the unit, as they may touch dangerous voltage points or short out parts that could result in fire or electric shock. Never spill liquid of any kind on or inside the unit.

Servicing - Servicing of the unit should only be undertaken by qualified service personnel, as opening or removing covers may expose you to dangerous voltages or other hazards.

2. INTRODUCTION

GENERAL

The Rx400DC receiver is designed to control DC-operated, high and variable speed pan/tilt heads and domes.

The Rx400DC receiver is supplied in an IP 67 rated enclosure. It will be necessary to make suitable holes in the enclosure to permit cable entry and exit. Adequately rated cable glands and or flexible conduit should be used at all times to avoid compromising the protection afforded by the enclosure as supplied. Any holes made in the enclosure for any other purpose should be sealed with a non-hardening water-proof sealant, taking care to ensure that the internal electronics are not contaminated.

The Rx400DC receiver can be used with the Tx400DC single camera telemetry controller and with any of the following BBV multi-camera telemetry transmitters, providing they are fitted with the DC option (joystick, high and variable speed):

TX1000/8 TX1000/16 TX1000/8A TX1000/16A TX1500

The slave keyboard Tx1000KBD can also be used, providing it is fitted with the DC option.

Rx400DC TECHNICAL SPECIFICATION

Power Requirements: 230 volts 50Hz. IEC connector provided.

Current Consumption: 100VA maximum

Maximum Load: 5 Amp.

Fuses: F1 Auxiliary fuse: 5A T
F2 Receiver fuse: 630mA T

Features:

- 24VDC outputs suitable for high and variable speed pan/tilt heads.
- Outputs for pan and tilt motor brakes as fitted to some DC pan/tilt heads.
- 12 volt DC output suitable for cameras, etc. (500mA max. load).
- 8 alarm inputs.
- 1 N/C alarm output, with programmable delay.
- Up to 16 full-scene pre-set positions can be stored within the Rx400DC.
- On-board photocell suitable for switching up to 1kW of lighting.
- Method of activating/controlling lighting output is programmable.
- Fine-settable low-speed response and settable maximum speed.

Engineering Facilities:

- Unit auto-tunes to the coaxial telemetry signal.
- LED readout for continual system status.
- Self test feature activates each function for two seconds in turn. See Fig. 4, page 11 for test sequence.
- Video launch amplifier provided with Gain and Lift controls.
- Colour-coded mains output terminal connections: Live, Neutral and Earth

Telemetry Signals: Telemetry signals either:
i) up the co-ax (designed to operate at 250M RG59/500M CT125);
or ii) via twisted pair 20mA loop.

Auto-Iris Output:	Returns to original setting 15 seconds after key release. Level is programmable from keypad. Will drive the override input for Cosmicar or Seiko-style lens.
Video Input:	1v p-p 75Ω terminated input via BNC socket.
Video Output:	1v p-p to 4v p-p 75Ω impedance via BNC socket.
Lens Drive:	Adjustable via control VR4 /LENS, and ranges between 3 and 12 volts. Inching speed adjustable control VR3/INCH between 0% and 100% of full lens voltage. One-second inching built in. Drives provided for Zoom, Focus and Auto-iris Over-ride . The Focus and Zoom lens drives each have a green LED and a red LED to indicate correct lens drive function.
Presets:	Inputs provided for preset feedback pots. These inputs are: 10-bit resolution, pan, tilt, zoom and focus. Up to 16 preset positions can be stored within the Rx. Each position consists of a complete view, i.e. pan, tilt, zoom and focus settings.
Dimensions (external):	Width: 190 mm Length: 380 mm Height: 130 mm
Weight:	2.8kg
Temperature range:	-10° Celsius to +40° Celsius

PROGRAMMABLE OUTPUT FEATURES

- Alarm output:**
- Alarm output activation may be:
 - i) immediately on alarm;
 - or ii) delayed until head approaches pre-set position
 This option is DIP switch selectable.
- Lighting output:**
- Lighting output may be:
 - i) immediate on alarm;
 - ii) manually controlled from Tx keyboard;
 - or iv) automatically controlled by dusk/dawn photocell.
 This option is DIP switch selectable.

Before using presets it is necessary to use the self test function, turn SW1 ON momentarily. During the course of the self test the receiver senses the feedback pot connections. If the cabling/travel is reversed then the unit will reset the relevant direction bits within the receiver. Subsequent searches to preset should now function correctly.

DO NOT PROGRAM PRESETS CLOSE TO PHYSICAL ENDSTOPS

CABLE CONNECTION METHOD

Fig. 1: Wago connectors

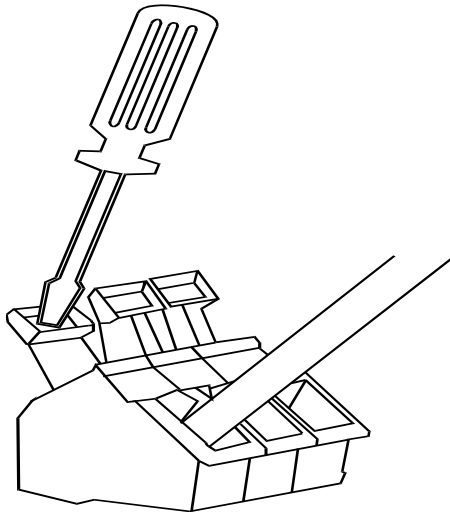

The WAGO series 256 PCB terminal block is a simple-to-use method of attaching cables to PCBs quickly and easily. Prepare cables as follows:

1. Use only cable between 0.08 and 2.5 mm²
2. Strip the cable to a length of 5 to 6 mm (0.23 in)

The correct method of attachment is as follows:

1. Press down the relevant terminal block lever with a suitable screwdriver;
2. Insert wire;
3. Remove screwdriver.

The procedure for detaching wires is the reverse of the 3 attachment steps, ensuring that **power is disconnected** before starting.

CABLING RECOMMENDATIONS FOR THE Rx RANGE OF RECEIVERS

Although BBV do not specify any particular type, manufacturer or supplier of cables, the following ESD Electronic Services (01279 626777) cables have been used successfully for production and testing:

ESD Part Number:	Description:
-------------------------	---------------------

071775G (100 m)	Output Cable 18-core 16/0.2mm PVC-insulated/PVC-sheathed cable Rated at 440 volts AC rms at 1600 Hz DEF 61-12 current rating per core 2.5 amp Maximum operating temperature: 70 degrees Celsius
--------------------	--

038309R (100 m)	Preset Cable 8-core 7/0.2mm PVC-insulated, overall braid screened Rated at 440 volts AC rms at 1600 Hz DEF 61-12 current rating per core 1.0 amp Maximum operating temperature: 70 degrees Celsius
--------------------	---

0222586G (100 m)	Co-Ax Cable (Minimum Specification) RG59B/U ESD radio frequency co-ax cable to BS2316 and MIL-C-17 1/0.58mm copper-covered steel wire conductor with solid polythene dielectric, bare copper wire braid and PVC sheath Characteristic impedance: 75 Ohm Capacitance: 22pF/ft
---------------------	--

020966D (100 m)	Orange-Coloured Lighting Output Power Cable (1000 w) 3183Y PVC-insulated, 3-core cable 1.25mm ² 40/0.2mm annealed copper conductor Current rating: 13 amp
--------------------	--

0140467H (100 m)	20mA Twisted Pair Cable (Minimum Specification) British Telecom spec CW 1308 2-core 1/0.5mm PVC-insulated Maximum conductor resistance at 20 degrees Celsius: 97.8 ohms/km
---------------------	--

3. INSTALLATION

OPERATING VOLTAGE

The Rx400DC requires all connections to the PCB to be made by the installer, and via terminal blocks or by plug and socket. These connections are: power in, video in, video out, alarm in, alarm out, pan, tilt, lens, preset and auxiliary outputs. See Fig. 2, page 9 for the correct connections.

The Rx400DC is supplied pre-configured to suit the application for which it is intended, i.e. to control a 24V DC-operated panning head or other equipment.

The unit is pre-wired as standard for **230 volt** mains operation.
Options are available at purchase time for 110Vac and 24Vac supply operation.

NOTE

With Issue 3 pcbs and Version 18 software, J10 zoom & focus preset inputs are swapped.
This is corrected in software version 19.

i.e. Issue 3 PCB and V18 software
Zoom preset I/P = J10 Pin 2 (FC)
Focus preset I/P = J10 Pin 3 (ZM)

CABLE CONNECTION INSTRUCTIONS

Fig. 2: Cable connection diagram

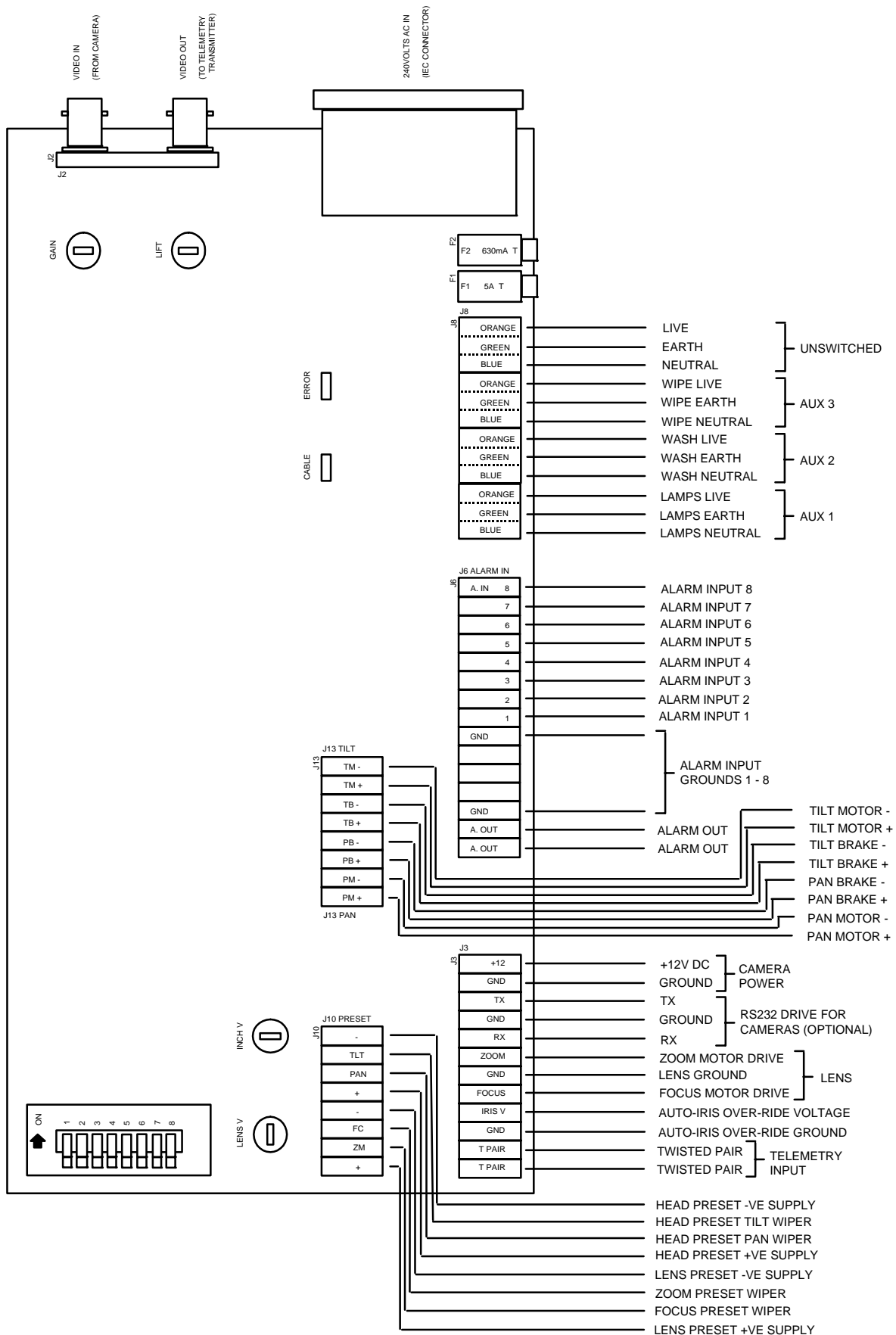

4. SETUP

DIAGNOSTIC AIDS

Two L.E.D.'s (Error and Cable) are mounted on-board to give simple system status information. Their functions are as follows:

Cable LED

Regular blinking - Telemetry and sync signals OK
Blinking but mainly ON - No telemetry information from the transmitter
Blinking but mainly OFF - No sync information from the camera

Error LED

On - Transmission error (e.g. framing error, parity error)

Both LED's

Off - No power or major PCB error

As all BBV equipment is designed to auto-tune and compensate for any discrepancies in the transmitter signal, there are no further adjustment that need to be made.

CABLE LENGTH COMPENSATION

There are two variable controls situated close to the BNC connector J1: Lift and Gain. These are pre-adjusted for a cable distance of 250M, and are adjustable to compensate for video detail or signal losses if and when longer or shorter cable lengths are used to connect the monitor to the receiver.

Fig. 3: Launch amplifier

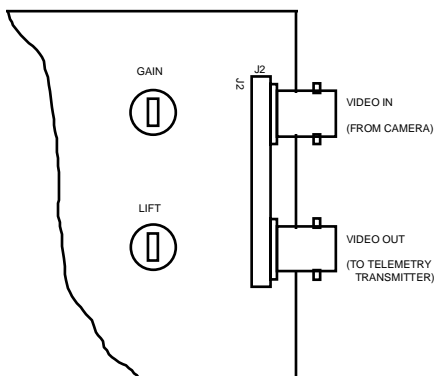

Default Position. For shorter cable lengths, turn the relevant control anti-clockwise until the required picture quality is obtained. For longer cable lengths, turn the relevant control clockwise until the required picture clarity is obtained.

The purpose of each control is:

Lift boosts the high-frequency signal
Gain adjusts the gain of the video signal

Attention: Ensure that the cable is terminated at the monitor end only.

SELF-TEST AND DIAGNOSTIC SEQUENCE

The diagnostic system-and-status check, which will activate each camera function for two seconds in turn, is activated either locally, by switching DIP switch 1 ON and immediately OFF, or remotely from a BBV keypad. When testing the system locally, before initiating the diagnostic system-and-status check, ensure that the Cable LED is **on** (i.e. either flashing or continuously). If not, this indicates that either the power is not connected to the PCB, or there has been a major PCB error. Rectify accordingly.

The Error LED flashes at a two-second rate during self-test. If the Cable LED fails to extinguish, then the unit is unable to self-tune and should be returned for repair.

Fig. 4: Self test sequence

Order of function test:

Functions tested:	Test points:
Camera moves right	J13 - 1 and 2
Camera moves left	J13 - 1 and 2
Camera moves down	J13 - 7 and 8
Camera moves up	J13 - 7 and 8
AUX Wiper	J8 - 9
AUX Wash	J8 - 6
AUX Lamps	J8 - 3
Lens zoom out	J3 - 7
Lens zoom in	J3 - 7
Lens focus near	J3 - 5
Lens focus far	J3 - 5
Auto-iris over-ride open	J3 - 4
Auto-iris over-ride close	J3 - 4
Alarm output	J6 - 1 and 2
Diagnostic check complete, unit resets and continues normal operation.	

N.B. If the receiver is connected to a Tx1000/8A or a Tx1000/16A or TX1500 with alarms telemetry transmitter, the Alarm output self test will generate an alarm condition at the Tx keyboard at the completion of the test, in order to test the continuity of the alarm wiring.

The pin-outs listed above as test points refer to connectors shown in Fig. 2 (cable connection diagram), on page 9. Note that the connectors are numbered from the left of the cable connection diagram in Fig. 2.

PROGRAMMING THE UNIT

Programming is carried out with the bank of 8 DIP switches at the top left hand corner of the PCB. See Fig. 2, on page 9.

The default setting for all 8 DIP switches is OFF, i.e. towards the left. The body of the switch bank is labelled ON to indicate that the ON position is to the right.

The switches control the following functions when the unit is in programming mode:

Switch 1	Switch ON and OFF activates self test.
Switch 2	Programme alarm output option: immediate or delayed. ON = delayed.
Switch 3	Activate Patrol mode. ON = activated.
Switch 4	Programme Datum operation.
Switch 5	Programme maximum and minimum speed response.
Switch 6	Programme twilight threshold setting.
Switch 7	Activate lens fine response (anti-hunting mode).
	(OFF = Response at ¼ Inch Speed. ON = Response at Inch Speed. OFF = Default setting.)
Switch 8	ON position selects Programming mode

The self test function can be activated before any programming is carried out, in order to verify that the unit is functional and to reset the unit prior to programming.

The first three settings to be programmed involve the adjustment of the Lens V and Inch V pots while in Programme mode. Make a note of the original settings for these pots as they must be returned to the original settings on exiting Programme mode.

Programming consists of the following steps, which should be carried out in the order specified:

1. Programme Datum Delay Operation:

Switch 8 ON	Enters Programming mode
Adjust Lens V pot as required	Sets Datum operation delay time (fully anti-clockwise = approx. 10 secs., fully clock-wise = approx. 20 mins.)
Switch 4 ON then OFF	Assigns selected delay time to Datum mode
Switch 8 OFF	Exits Programming mode
Return Lens V pot to previous position.	

N.B. Datum is a "Self-park" position stored in Pre-set 1. Datum operation must be selected ON for normal operation after programming is completed, before the above settings are utilised by the unit. See SETTINGS FOR NORMAL OPERATION, Page 14.

2. Programme maximum and minimum speed response:

Switch 8 ON	Enters Programming mode
Adjust Inch V pot as required	Sets slow speed response
Adjust Lens V pot as required	Sets high speed response
Switch 5 ON then OFF	Stores maximum and minimum speed settings
Switch 8 OFF	Exits Programming mode
Return both pots to previous positions	
Check preset operation still works.	

N.B. If slow speed response is set too slow, either of the following symptoms may be experienced:
Control of head may be lost due to motor stall or preset operation may be intermittent or slow.

If the response is set too fast, then it is possible for the head to hunt during a preset operation.

3. Programme twilight threshold setting: (Not supported on iss2 and later pcbs)

Switch 8 ON	Enters Programming mode
Adjust Lens V pot as required	Sets twilight threshold (anti-clockwise = twilight threshold darker)
Switch 6 ON then OFF	Stores twilight threshold adjustment setting
Switch 8 OFF	Exits Programming mode
Return Lens V pot to previous position.	

4. Programme alarm output option:

Switch 8 ON	Enters Programming mode
Switch 2 OFF then ON	Selects delayed alarm output
Switch 8 OFF	Exits Programming mode
Switch 2 OFF	Default setting

N.B. For a new unit, this step should be omitted if immediate alarm output activation is required. However, for a previously programmed unit, the following steps revert from delayed alarm output to immediate output operation:

Switch 8 ON	Enters Programming mode
Switch 2 ON then OFF	Returns unit to default setting (immediate alarm output)
Switch 8 OFF	Exits Programming mode

5. Activate Patrol Always mode:

Switch 8 ON	Enters Programming mode
Switch 3 OFF then ON	Activates Patrol mode
Switch 8 OFF	Exits Programming mode
Switch 3 OFF	Default setting

N.B. For a new unit this step should be omitted if Patrol Always mode is not to be used. However, for a previously programmed unit, the following steps revert from Patrol Always = ON to the default setting (Patrol Always = OFF):

Switch 8 ON	Enters Programming mode
Switch 3 ON then OFF	Returns unit to default setting (Patrol Always mode = OFF)
Switch 8 OFF	Exits Programming mode

See SETTINGS FOR NORMAL OPERATION, Page 14, for a fuller explanation of Patrol Always mode.

6. Activate lens fine response:

Switch 8 ON	Enters Programming mode
Switch 7 OFF then ON	Activates lens fine response mode (anti-hunting mode for lenses with sluggish response)
Switch 8 OFF	Exits Programming mode
Switch 7 OFF	Default setting

N.B. For a new unit this step should be omitted if lens fine response mode is not to be used. However, for a previously programmed unit, in order to revert to the default setting , the following steps should be carried out:

Switch 8 ON	Enters Programming mode
Switch 7 ON then OFF	Returns unit to default setting
Switch 8 OFF	Exits Programming mode

Once all programme settings are complete, the DIP switches can be set for their desired normal operational modes. This is done with DIP switch 8 in the OFF (left) position. See SETTINGS FOR NORMAL OPERATION, Page 14.

SETTINGS FOR NORMAL OPERATION

Several functions have more than one setting available for normal operation. These Settings for normal operation can only be made when all programming settings have been carried out and programme mode has been exited.

The DIP switches are used to select these settings as follows:

Switch 1	Switch ON then OFF activates self test.
Switch 2	Reverses zoom motor direction. ON = reversed.
Switch 3	Reverses focus direction. ON = reversed.
Switch 4	Select iris-override voltage range. OFF = 2.5 - 12V , ON = 2.5 - 5.5V
Switch 5}	See table below. (<i>optional Photocell operation - requires photocell and clear box lid</i>)
Switch 6}	See table below.
Switch 7	Activates Datum operation. ON = Datum activated.
Switch 8	OFF position selects normal operating mode.

Table of settings for Switches 5 and 6:

Switch 5:	Switch 6:	Setting selected:
OFF	OFF	AUX 1 (lamps) output has normal, latching operation using LIGHTS button
OFF	ON-AUX 1	AUX 1 (lamps) output is controlled by the photocell only (not supported with iss 2 pcb)
ON	OFF	AUX 1 (lamps) output is controlled by alarm input(s)
ON	ON	AUX 1 becomes a spare momentary output

N.B. Before starting, ensure that DIP switch 1 is in the OFF (left) position.

Once all the required operating settings have been selected, a self test can be performed to test the programming and operation of the unit.

PATROL MODE AND DATUM OPERATION

Note also the following points relating to Patrol mode and Datum operation.

It is possible to initiate a Patrol manually from the Tx telemetry transmitter keyboard, even if Patrol Always mode is not selected through the DIP switch settings on the receiver. Refer to the relevant Tx telemetry transmitter manual for further details.

There are two separate Patrols available to the operator from the Tx telemetry keyboard (Patrol 1 and Patrol 2).

When the receiver executes a Patrol, the unit cycles round all stored pre-sets, starting always with pre-set 1. The Tx1000 telemetry transmitter permits the operator to store up to 16 pre-sets in the receiver.

The Tx400 telemetry transmitter allows the operator access to only the first 8 pre-sets.

Storing pre-sets in the receiver automatically adds those pre-sets to Patrols 1 and 2.

Individual pre-sets can be removed from either Patrol 1 or Patrol 2 using the Tx telemetry transmitter keyboard, in order to allow the operator to create two different Patrol sequences.

Independent delays (pauses between pre-set activations) are available for each Patrol, programmable from the Tx telemetry transmitter keyboard.

If Patrol Always mode is selected, the unit returns to Patrol mode following a power loss (starting with pre-set 1).

If Patrol Always mode is selected, the unit reverts to Patrol mode after manual operation ceases, following a delay.

Manual operation takes priority over a Patrol.

Patrol Always mode permits the installation and operation of a system with no Tx telemetry transmitter keyboard fitted for an operator.

Care should be taken before programming the receiver for Patrol Always, since this cannot be de-activated from the Tx telemetry keyboard.

Patrol Always can only be de-activated by programming the receiver DIP switches.

Programming the receiver for Datum = ON over-rides Patrol mode.

If Datum is set to ON, the unit remains in that mode following a power loss.

Patrol Always

To start patrol always mode

1. Program dip switches, see page 13, section 5.
2. Start patrol 1 on Keypad, this safety feature stops the head moving until Patrol manually started. However the head may move at any time once the Patrol has been activated, after power down etc.

To stop patrol always mode

1. Program dip switches, see page 13, section 5.
2. Stop the Patrol from a Keypad, by panning or tilting the head.

PRESETS ON THE Rx400DC

When using presets ensure correct connection of the feedback pots. Pay particular attention to ensuring that power is not connected across one end of the pot and the wiper, as damage to the feedback pot may ensue.

Beyond connecting the correct wiper to each function input, i.e. focus wiper to focus input etc., the installer does not need to worry about reversing the polarity/direction of travel. If, for instance, the pan/tilt head has been installed upside down, the receiver will compensate for this arrangement.

Before using presets it is necessary to use the self test function, turn SW1 ON momentarily. During the course of the self test the receiver senses the feedback pot connections. If the cabling/travel is reversed then the unit will reset the relevant direction bits within the receiver. Subsequent searches to preset should now function correctly.

DO NOT PROGRAM PRESETS CLOSE TO PHYSICAL ENDSTOPS (pan/tilt/zoom /focus)

Options:

- 1) Photocell / Clear box lid to allow cost effective switching of the lights relay using an on board photocell. This is a zero cost option which must be specified at order time. Please amend -Photocell to part code.
- 2) Serial control of Mitsubishi CCD400 integrated camera. Full lens control, preset positioning, shutter speed and backlight compensation can all be controlled using a simple 3 wire serial connection; +12Vdc, Gnd, Data. Please amend -Mitsi to part code.
- 3) Serial control of the JVC TK-C1360E advanced frame integration camera. Full access to the camera on screen menu is provided in a addition two scenes can be programmed. A scene comprises the current camera settings, allowing a night and day setup. Please amend -JVC to part code.

Manual revisions

- 2 original combined manual
- 2a Fixed Rx200Mk2 autopan/washer & wiper connection details – pages 5 & 6
Fixed Rx400P zoom/focus reverse switch details – pages 15 & 16
Fixed Rx400DC Zoom & Focus preset input connection details – page 24
- 3 Added 2 addition pages for Rx400P Mark II issue 5 pcb details – page 18
Inserted safety notices on page 2
- 4 Inserted installation instructions for PCB-based Receivers

INSTALLATION INSTRUCTIONS FOR PCB-BASED RECEIVERS

WARNING: THIS EQUIPMENT MUST BE EARTHED.

1. When mounting BBV receivers on metalwork, it is essential to maintain correct earthing
2. **CORRECT CLEARANCE.** Metal spacers M3 x 10mm long should be used to mount the PCB on the metalwork. These should be earthed to ensure optimum performance. Spacers of the correct length will ensure that minimum air gaps are exceeded.
3. Use all of the mounting points to ensure adequate support with minimum flexing when connections are made to the unit. See diagram.
4. In case of queries, technical assistance is available on +44 (0)1323 842727.

Metalwork Drilling Details

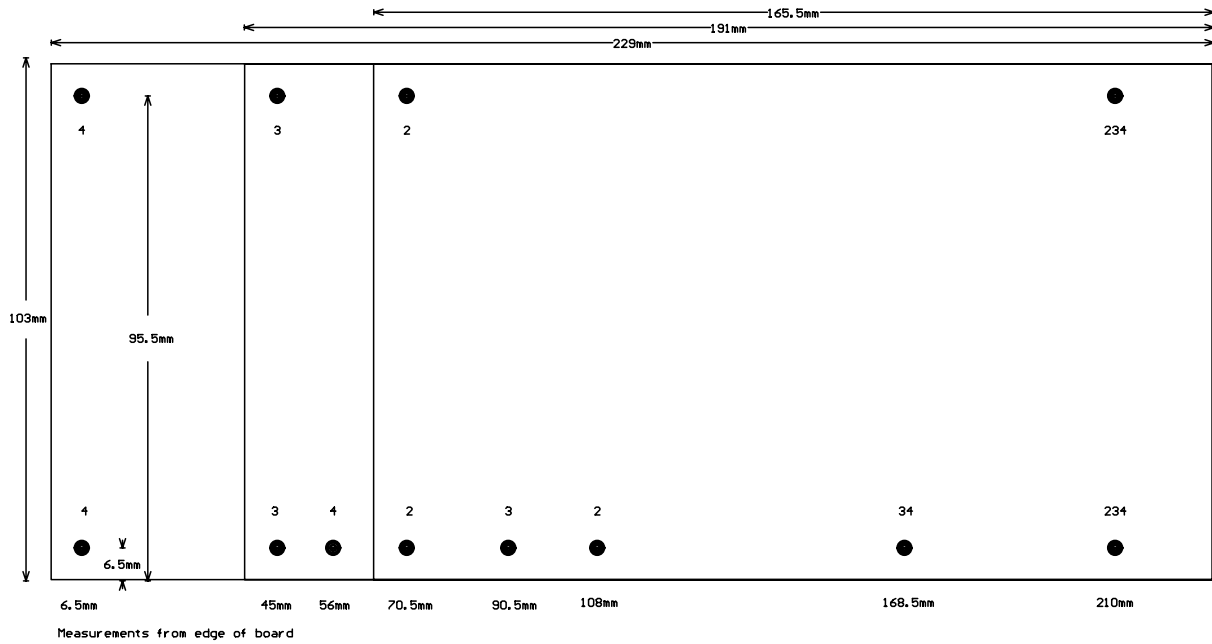



BBV Example telemetry system configuration

Building Block Video Ltd, 17 Apex Park, Hailsham, East Sussex, BN27 3JU UK. Tel:+44(0)1323 842727 Fax:+44(0)1323 842728 Support:+44(0)1323 444600 14/12/00 PSC
web site: www.bbvctv.com email sales@bbvctv.com

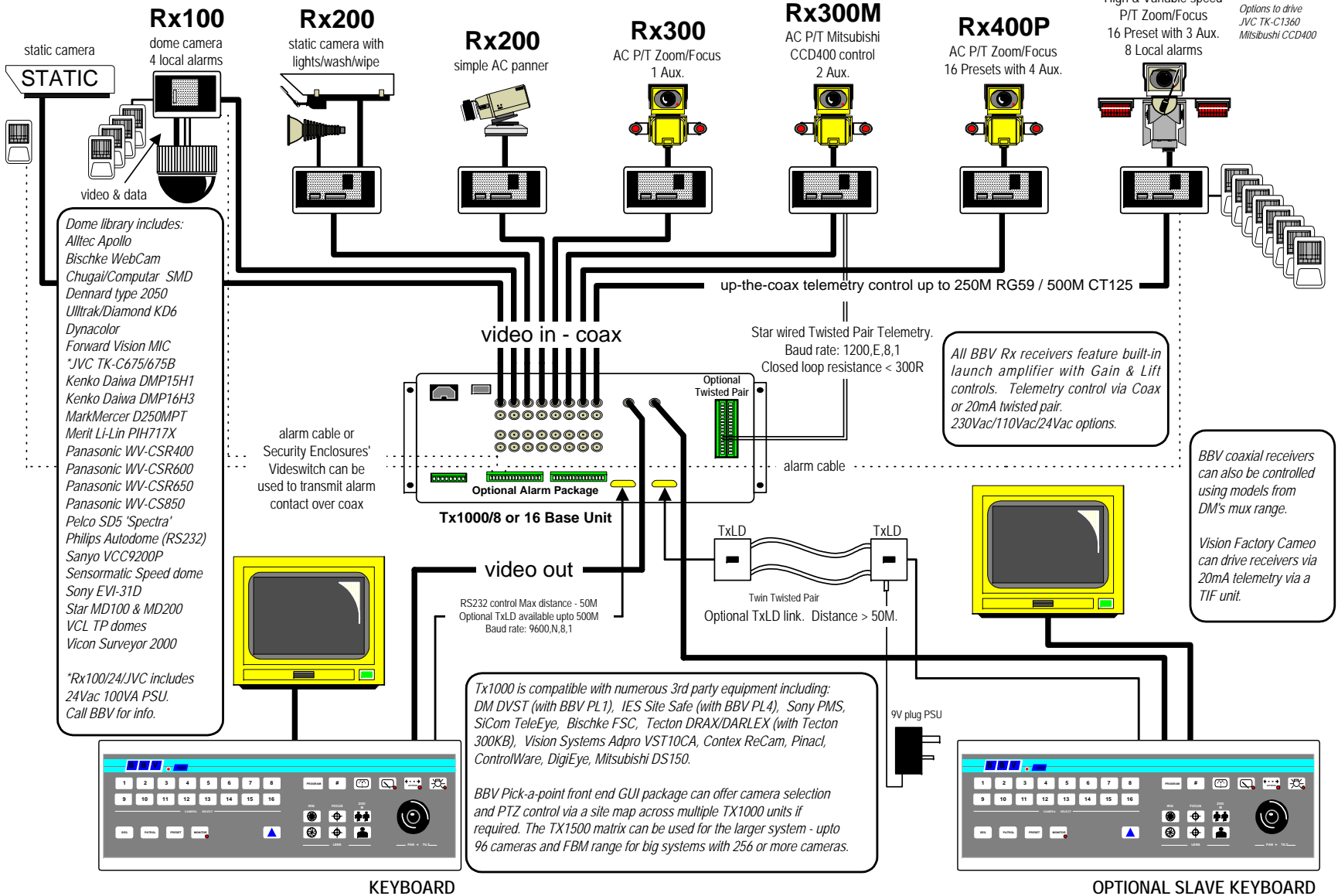



BBV TX1500 example

Building Block Video Ltd, 17 Apex Park, Hailsham, East Sussex, BN27 3JU UK. Tel:+44(0)1323 842727 Fax:+44(0)1323 842728 Support:+44(0)1323 444600
web site: www.bbvctv.com email sales@bbvctv.com

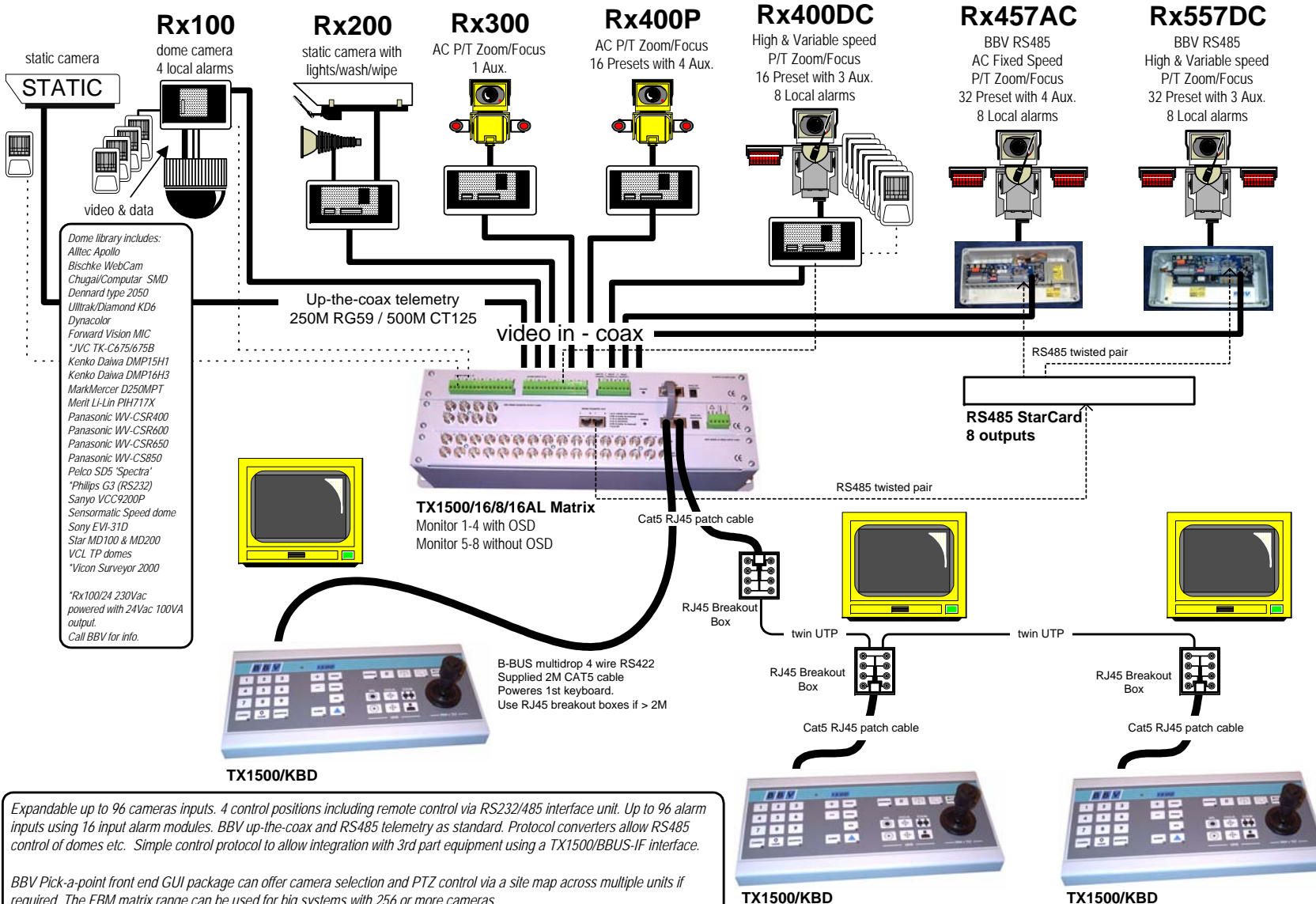

- This page is blank for your notes -

- This page is blank for your notes -

- This page is blank for your notes -

The BBV product range.

Product	Description
TX300	Single camera desktop telemetry transmitter with coax & 20mA telemetry, Pan/Tilt/Lens & Lights
TX400	As TX300 inc Wash, Wipe, Autopan, 8 presets, preset patrol.
TX400DC	As TX400 including joystick for proportional Pan/Tilt control.
TX1000	8 or 16 camera, 2 monitor telemetry transmitter. Up to 2 keyboards and options for alarm inputs and 20mA telemetry.
TX1500	Mid size matrix 16 – 96 camera, 8 monitor. Up to 4 control positions (keyboard & remote control) options for alarms, remote control, coax and RS485 telemetry.
FBM range	Large size matrix. Configurable up to 1024 cameras and 64 monitor outputs. Up to 8 control positions (keyboard & remote control) options for alarms, remote control RS485 telemetry with various options.
RX100	Dome Interface with options to drive a large library of dome cameras. Coaxial and 20mA telemetry.
RX200	AC receiver for Pan only heads or static cameras, Wash/Wipe/Lights. Coaxial and 20mA telemetry.
RX300	AC receiver for Pan/Tilt/Zoom/Focus/Iris Override and 1 Auxiliary output. Coaxial and 20mA telemetry.
RX400P	AC full function receiver. PTZFI 4 Auxiliary outputs, 16 presets. Coaxial and 20mA telemetry.
RX400DC	24Vdc high/variable speed receiver. 16 presets, 8 local alarm inputs, 3 Auxiliary outputs, options to drive JVC TK-C1360 and Mitsi CCD400 cameras. Coaxial and 20mA telemetry.
RX45X - RX55X Multi protocol RS485 and BBV coax	RS485 and BBV coa controllable AC and DC receivers. These receivers are controlled from an expanding choice of RS485 protocols as listed below. 110/230Vac supply. PTZFI, 32 presets, preset patrol, 8 local alarm inputs, 12V 500mA supply output. OSD for remote diagnostics. 3 Auxiliary outputs. Optional Privacy board. BBV RS485 and COAX, PELCO P/D RS485, VCL RS485, PHILIPS RS485 (OPTIONAL BI-PHASE INPUT), DENNARD RS485
RX450/550	PANASONIC RS485 Protocol only version of RX45X/55X.
STARCARD	8 * RS485 output with option of protocol conversion. STARCARD/CONVERTER
ACCESSORIES	TxLD (bidirectional RS422-RS232 converter) 98005 (bidirectional 20mA-RS232 converter)