



DMP124

Philips G3 Dome Interface



Installation Guide



Building Block Video Ltd.,
17 Apex Park,
Diplocks Industrial Estate,
Hailsham, East Sussex, BN27 3JU UK.
Tel: +44(0)1323 842727
Fax: +44(0)1323 842728
Support: +44(0)1323 444600
www.bbvctv.com

TABLE OF CONTENTS

1. Pre-installation Checks and Safety Procedures	3
Unpacking	3
Important safety precautions	3
2. Introduction	5
General	5
DMP124 Technical specification	5
Cable connection method	6
<i>Fig. 1 Wago cable connectors</i>	
Cable types	6
3. Installation	7
DMP124 connections	7
<i>Fig. 2a DMP124 230Vac Supply operation connection details</i>	7
<i>Fig. 2b DMP124 24Vac Supply operation connection details</i>	7
<i>Fig. 3 DMP124 PCB connections</i>	8
4. Setup	9
Diagnostic aids	9
Cable length compensation	9
<i>Fig. 4 Launch amplifier</i>	
5. System schematic diagrams	10
<i>Fig. 5 Dome end wiring</i>	
<i>Fig. 6 Integration of dome into conventional system</i>	
6. Configuring the dome and DMP124 links	11
J6 Configuration links	11
Using a TX1000DC to access the advanced features	11
Using a TX400DC to access the advanced features	12
Using a DM Sprite/DSL/DS/DS2 to access the advanced features	13
7. Troubleshooting	
Basic troubleshooting	14

1. PRE-INSTALLATION CHECKS AND SAFETY PROCEDURES

UNPACKING

Check Packaging - Upon taking delivery of the unit, inspect the packaging for signs of damage. If damage has occurred, advise the carriers and/or the suppliers immediately.

Check Contents - Upon taking delivery of the unit, unpack the unit carefully and check that all the items are present and correct. If any items are missing or damaged, contact your equipment dealer.

Retain Packaging - The shipping carton is the safest container in which to transport the unit. Retain undamaged packaging for possible future use.

IMPORTANT SAFETY PRECAUTIONS

Read Instructions - All relevant safety, installation and operating instructions should be read before attempting to install, connect or operate the unit.

Retain Instructions - All safety, installation and operating instructions should be retained for future reference.

Heed Warnings - All warnings on the unit and in any relevant safety, installation or operating instructions should be adhered to.

Cleaning - Unplug the unit from the power outlet before cleaning. Do not use liquid cleaners or aerosol cleaners. Use a damp cloth for cleaning.

Attachments - Do not use attachments not recommended by the product manufacturer as they may cause hazards.

Water and Moisture - Do not expose the internal electronics of this unit to water or dampness; for example, in an unprotected outdoor installation, or in any area classified as a wet location. The unit as supplied conforms to ingress protection rating IP 67. This rating will be affected by any holes made in the enclosure. Cable entry points should be protected by the use of suitably rated glands and/or flexible conduit. It is not necessary to make further holes in the enclosure for mounting purposes, as mounting holes are provided at the corners of the enclosure outboard of the seal between enclosure and lid.

Accessories - Do not attach this unit to an unstable stand, bracket or mount. The unit may fall, causing serious injury to a person and serious damage to the unit.

Power Sources - This unit should be operated only from the type of power source indicated on the manufacturer's label. If you are not sure of the type of power supply you intend to use, consult your equipment dealer or local power company. For units intended to operate from battery power or other sources, refer to operating instructions.

Power Connector - This unit is equipped with coaxial power connector mounted at the edge of the PCB for low voltage power input. Do not attempt to alter this connector in any way.

Power Cord Protection - Power supply cords should be routed so that they are not likely to be trapped, pinched or otherwise damaged by items in close proximity to them, whether inside the unit or outside it. Particular attention should be paid to cords at plugs, connection units and the point of exit from the unit.

Overloading - Do not overload outlets and extension cords, as this can result in fire or electric shock.

Object and Liquid Entry - Never push objects of any kind into the unit, as they may touch dangerous voltage points or short out parts that could result in fire or electric shock. Never spill liquid of any kind on or inside the unit.

Servicing - Servicing of the unit should only be undertaken by qualified service personnel, as opening or removing covers may expose you to dangerous voltages or other hazards.

Damage Requiring Service - Servicing by qualified personnel should be carried out under the following conditions:

- (a) When the power-supply cord or plug is damaged.
- (b) If liquid has been spilled or objects have fallen into the unit
- (c) If the internal electronics of the unit have been exposed to rain or water
- (d) If the unit does not operate normally by following the operating instructions. Adjust only those controls that are covered by the operating instructions, as improper adjustment of other controls may result in damage and will often require extensive work by a qualified technician to restore the unit to normal operation.
- (e) If the unit has been dropped or the enclosure is damaged.
- (f) If the unit exhibits a distinct change in performance. This indicates a need for service.

Replacement Parts - If replacement parts are required, ensure that only replacement parts recommended by the product manufacturer are used.

Safety Check - Upon completion of any service or repairs to the unit, safety checks should be performed to ensure that the unit is in proper operating condition.

Pre-installation Checks - It is recommended that the unit be bench-tested prior to installation on the site.

Safety During Installation or Servicing - Particular care should be taken to isolate the dome in order to prevent operation while engineering work is being carried out on the unit.

Adhere to Safety Standards - All normal safety precautions as laid down by British Standards and the Health and Safety at Work Act should be observed.

WARNING

TO PREVENT DANGER OF FIRE OR SHOCK, DO NOT EXPOSE THE INTERNAL COMPONENTS OF THIS EQUIPMENT TO RAIN OR MOISTURE.

The “lightning flash with arrowhead” symbol inside an equilateral triangle is used to warn the user of this equipment that there are sufficiently high voltages within the enclosure to constitute a risk of electric shock.

The “exclamation point” symbol inside an equilateral triangle is used to alert the user of this equipment to important operating and maintenance (servicing) instructions in the literature accompanying the appliance.

2. INTRODUCTION

GENERAL

The DMP124 telemetry interface is designed to allow control of the Philips G3 series of autodomies from control systems that use BBV coaxial telemetry. Products that support BBV coaxial telemetry include BBV TX400DC/TX1000DC/TX1500/FBM, Dedicated Micros System Sprite/Digital Sprite, Adpro AMUX, Dennard dTx400PJ/dTx1000PJ/dTx1500.

The interface is supplied in an IP67 rated external enclosure. It will be necessary to make suitable holes in the enclosure to permit cable entry and exit. Adequately rated cable glands and or flexible conduit should be used at all times to avoid compromising the protection afforded by the enclosure as supplied. Any holes made in the enclosure for any other purpose should be sealed with a non-hardening waterproof sealant, taking care to ensure that the internal electronics are not contaminated.

DMP124 TECHNICAL SPECIFICATION

Power Requirements:

- 230Vac 630mA inc 24Vac 100VA output to power dome
- or 24Vac 200mA max

Features:

- RS232 Serial data output
- 4 alarm inputs. (Volts Free Normally Closed – Open to generate alarm)
- 1 Normally Closed Alarm Output.
- Up to 16 pre-set positions
- Access of dome's menu
- Up to 16 pre-set positions
- 24Vac 100VA output to power dome

Engineering Facilities:

- Unit auto-tunes to the coaxial telemetry signal.
- Multiple LEDs for continual system status.
- Video launch amplifier provided with Gain and Lift controls.

Telemetry Signals: Telemetry signals either:

- BBV up-the-coax FSK.(Designed to operate with up to 250m of RG59 coax, 500M of CT125)
- or BBV 20mA twisted pair.

Video Input: 1v p-p 75Ω terminated input via BNC socket.
Video Output: 1v p-p to 4v p-p 75Ω impedance via BNC socket.

Dimensions (external): Width: 190 mm
Length: 380 mm
Height: 130 mm

Weight: 3.6Kg

Temperature range: -10°C to +40°C

CABLE CONNECTION METHOD

Fig. 1: Wago connectors

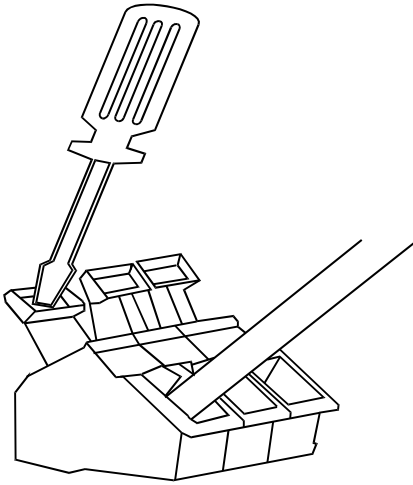

The WAGO PCB terminal block is a simple-to-use method of attaching cables to PCBs quickly and easily. Prepare cables as follows:

- Use only cable between 0.08 and 2.5 mm²
- Strip the cable to a length of 5 to 6 mm (0.23 in)

The correct method of attachment is as follows:

1. Press down the relevant terminal block lever with a suitable screwdriver;
2. Insert wire;
3. Remove screwdriver;

The procedure for detaching wires is the reverse of the 3 attachment steps, ensuring that **power is disconnected** before starting.

CABLING RECOMMENDATIONS FOR THE DM124 INTERFACE.

Although BBV do not specify any particular type, manufacturer or supplier of cables, the following ESD Electronic Services (01279 626777) cables have been used successfully for production and testing:

ESD Part Number:	Description:
-------------------------	---------------------

0222586G (100 m)	
---------------------	--

	Coax Cable (Minimum Specification)
--	---

	RG59B/U ESD radio frequency coax cable to BS2316 and MIL-C-17 1/0.58mm copper-covered steel wire conductor with solid polythene dielectric, bare copper wire braid and PVC sheath Characteristic impedance: 75 Ohm Capacitance: 22pF/ft
--	---

0140467H (100 m)	
---------------------	--

	20mA Twisted Pair Cable (Minimum Specification)
--	--

	British Telecom spec CW 1308 2-core 1/0.5mm PVC-insulated Maximum conductor resistance at 20 degrees Celsius: 97.8 ohms/km
--	--

3. INSTALLATION

CONNECTIONS

The unit requires all connections to the PCB to be made by the installer, and via terminal blocks or by plug and socket. These connections are: power in, video in, video out, and serial data to dome. In addition connections for alarm in, alarm out if required are provided. See fig.2 below for correct connections.

The DMP124 is supplied pre-configured to suit the application for which it is intended, i.e. to control an Philips G3 autodome camera.

The unit can be powered from either 230Vac or 24Vac and the following diagrams show the connection arrangements for each supply voltage.

Fig 2a. DMP124 Connection details when operating from a 230Vac supply.

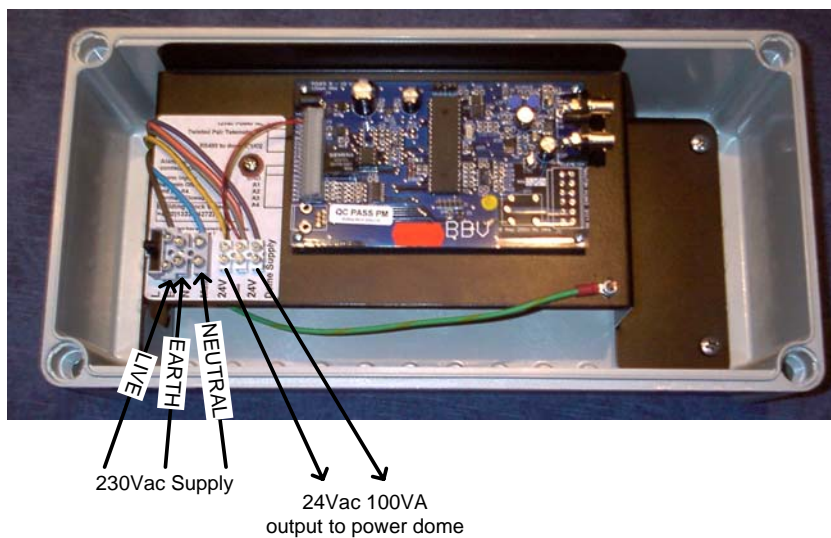

Important! When operating the unit from 24Vac, the fuse from the 230Vac connector fuse holder must be removed. No connections must be made to this connector as it will have 230Vac across the L & N terminals.

Fig 2b. DMP124 Connection details when operating from a 24Vac supply.

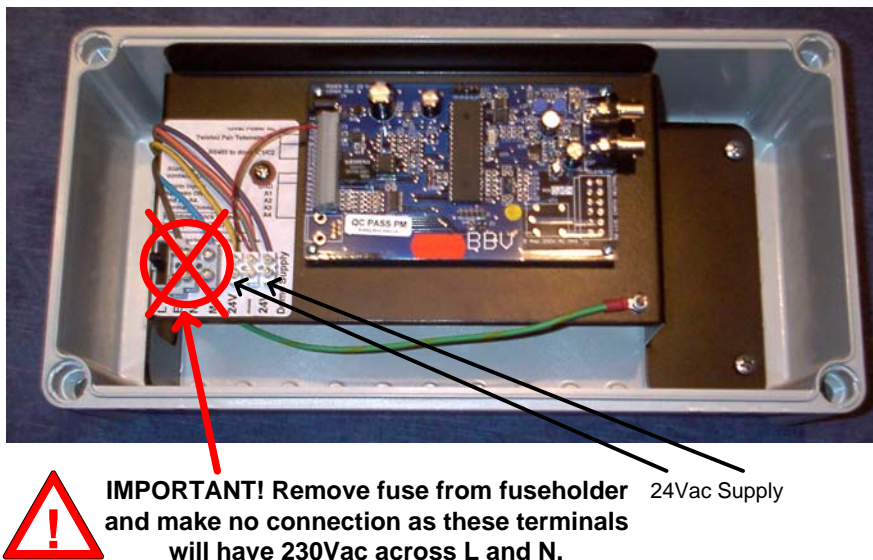
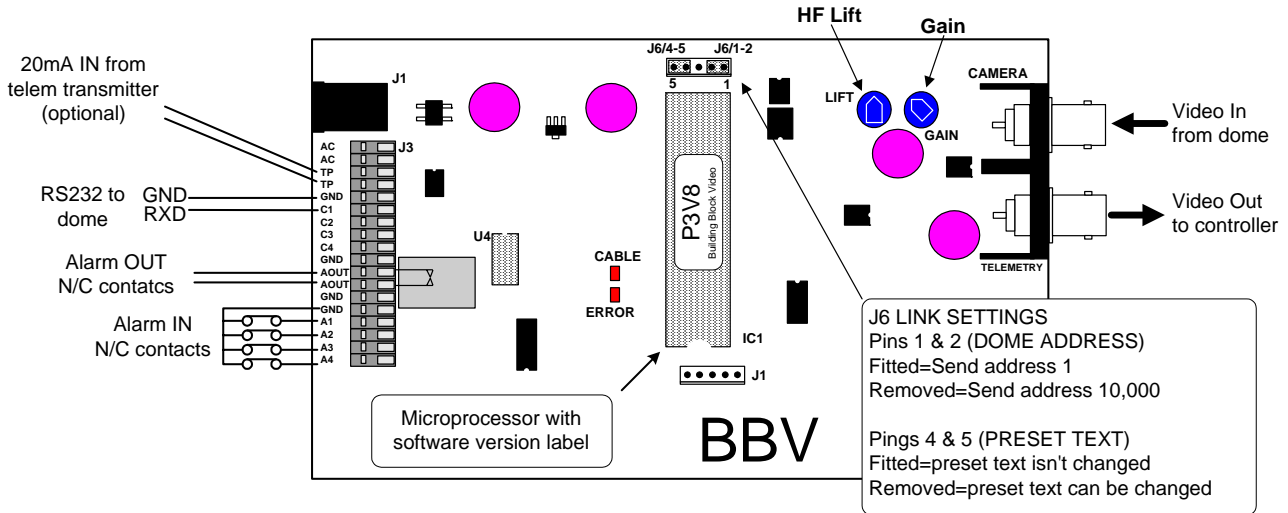

Fig. 3 DMP124 PCB connections



Function	Connector	Type
Video In	CAMERA	BNC SOCKET
Video Out	TELEMETRY	BNC SOCKET
Twisted Pair Telemetry	J3/TP & TP	Grey WAGO (optional if using 20mA telemetry)
RS232 to dome	J3/C1	Grey WAGO Connect to RXD of the dome
Ground to dome	J3/GND	Grey WAGO Connect to GND of the dome
Alarm 1 contact in	J3/A1 & GND	Grey WAGO (optional if alarm input required)
Alarm 2 contact in	J3/A2 & GND	Grey WAGO (optional if alarm input required)
Alarm 3 contact in	J3/A3 & GND	Grey WAGO (optional if alarm input required)
Alarm 4 contact in	J3/A4 & GND	Grey WAGO (optional if alarm input required)
Alarm contact out	J3/AOUT & AOUT	Grey WAGO (optional if alarm input required)

Operation modes.

Dome interface mode.

Fit link J6/1-2 when controlling the dome via BBV up-the-coax from BBV or DM equipment. Each dome must be addressed as either 0000 or 0001.

Alarm interface mode.

Remove link J6/1-2 when the dome is controlled using bi-phase Philips telemetry and the DMP124 is used as a 4 input alarm card to move the dome to preshot positions. Each dome that is connected to the bi-phase network must have a unique address. The DMP124 will send data to address 10,000 which is the dome global address. This may not work with old versions of dome. Please check with your Philips support contact.

4. SETUP

DIAGNOSTIC AIDS

Two LEDs are mounted on-board to give system status information. Their functions are as follows:

Cable LED

- Blinking equal ON and OFF - Telemetry and video signals are OK.
- Blinking but mainly ON - No Telemetry from the transmitter.
- Blinking but mainly OFF - No video from the camera.

Error LED

- On - Telemetry transmission error.

Both LEDs

- Off - No power or major PCB fault.

All BBV equipment is designed to auto-tune and compensate for any discrepancies in the transmitted telemetry signal, there are no further adjustments that need to be made.

VIDEO LAUNCH AMPLIFIER AND CABLE LENGTH COMPENSATION

The interface features a video launch amplifier with two variable controls situated close to the BNC connectors: Lift and Gain. These are pre-adjusted for a cable distance of 500m of CT125, are and adjustable to compensate for video detail or signal losses if and when longer or shorter cable lengths are used to connect the telemetry transmitter to the interface.

Fig. 4 Launch Amplifier

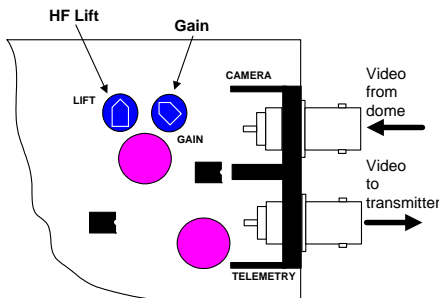

The purpose of each control is:

GAIN varies the overall signal level.

LIFT boosts the high frequency component of the video signal. If the high frequency component is too low, picture appears 'washed out' and lacking detail.

For shorter cable lengths, turn the Gain control anti-clockwise until 1V p-p is present at the telemetry transmitter. For longer cable lengths, turn the Gain control clockwise until 1V p-p is present at the telemetry transmitter.

5. SYSTEM SCHEMATIC DIAGRAMS

Fig. 5 Dome end wiring

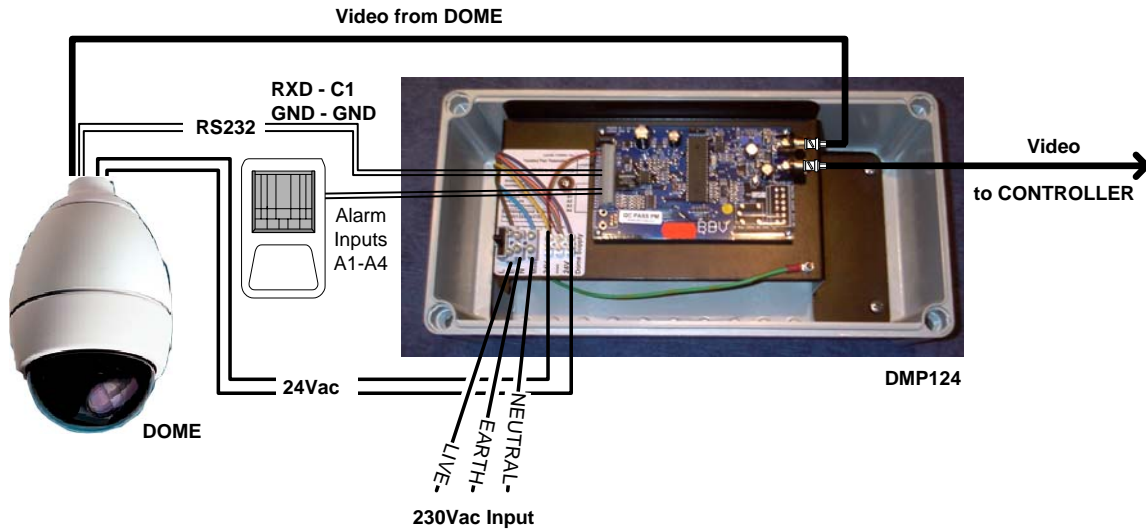
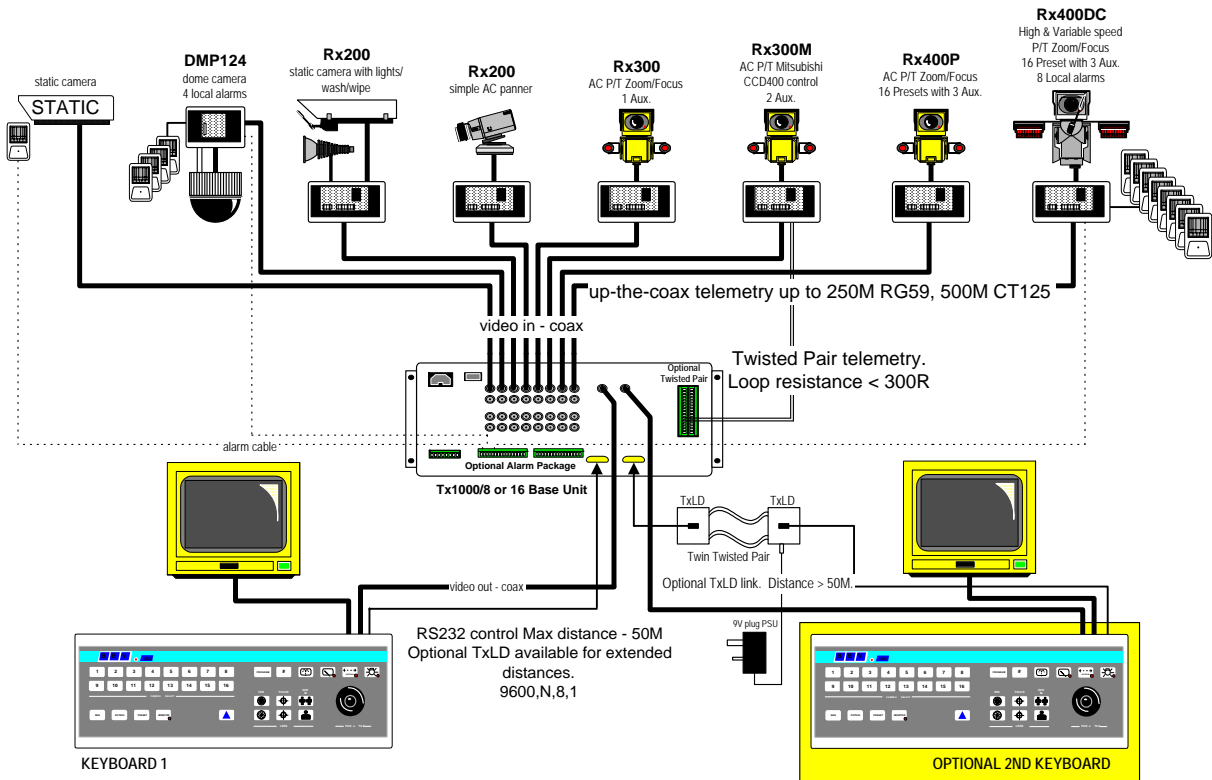

Fig. 6 SYSTEM SCHEMATIC SHOWING INTEGRATION OF DOME INTO CONVENTIONAL SYSTEM.



CONFIGURING THE DOME AND DMP124 LINKS.

Configuration links:

J6/pin 1-2 (Pin 1 nearest to BNCs)

used to select the address that the unit outputs. When the DMP124 is used simply for alarms then remove the link.

Fitted(Default) = Address 1, Removed = Address 10,000.

Removing the link allows the receiver to be used as an alarm input unit for domes that are controlled using bi-phase telemetry.

This will work with late model domes with post 2002 software.

J6/pin 4-5 (Pin 5 furthest from BNCs)

Removed – preset title text is programmed following a save preset command by automatically issuing a aux(62) command.

Fitted(Default) – the preset text command is not sent and the existing text is retained.

The alarm output relay opens for approx 5 seconds upon power up. This can be used to signal power loss, etc.

The dome must be RS232 controllable. BI-PHASE domes cannot be controlled.

Dome settings: Set the dome address to 0000 or 0001. Communications must be 9600, N, 8, 1. The G3 Basic address is software programmable, however as default the dome is addressed as 0000. If the dome address is not 0000 or 0001 then the dome will require reprogramming using a Philips controller or removing link J6/1-2 which will allow all domes to be controlled regardless of their address.

The following table shows the features that are available and the keystrokes that should be used when using BBV and DM controllers.

Advanced Features	BBV Tx1000	BBV Tx400	DM Sprite	DSL/DS/DS2
Display Menu (Aux 46)	# WASH	# 1	*889 002	*889 10 10 2
Program Zone Title (Aux 63)	# WIPE	# 2	*889 003	*889 10 10 3
Record AutoPlay start/stop (Aux 100)	# AUTOPAN	# 3	*889 004	*889 10 10 4
RESET DOME! (Set 899)	# LIGHTS	# 4	*889 005	*889 10 10 5

USING A TX1000DC TO ACCESS THE ADVANCED FEATURES

Menu Access:

Press and HOLD # and tap WASH TWICE will display the dome's menu.

Use the joystick to navigate the cursor. **FOCUS FAR** or **FOCUS NEAR** can be pressed to enter the next menu item or to return press either **IRIS OPEN** or **IRIS CLOSE**. When completely out of the menu issue a goto preset command to put the interface into normal mode. Press and HOLD **PRESET** whilst tapping **1** will move to preshot 1.

Program Zone Title:

Press and HOLD # and tap WIPE will allow the title for the current zone to be programmed.

Use the joystick as described on screen. Use the following keystrokes to program the text:

FOCUS NEAR – Select a current character, **FOCUS FAR** – Clear character, **IRIS CLOSE** – Backspace and **IRIS OPEN** – Return

Record Autoplay:

Press and HOLD # and tap AUTOPAN will allow autoplay 'A' to be recorded.

Press **FOCUS FAR** or **FOCUS NEAR** to start the recording or **IRIS CLOSE** to abandon recording. Once recording has started, use the joystick and focus keys as required. To end the recording, press and **HOLD #** and tap **AUTOPAN**. The recording can be replayed continuously by pressing the **AUTOPAN** key.

Reset dome defaults: USE WITH EXTREME CARE AS ALL THE DOME PROGRAMMING WILL BE LOST.

Press and HOLD # and tap LIGHTS TWICE to display the dome's software version. Repeating the key strokes for a THIRD time will issue a SET 899 to reset the dome including ALL PRESHOT POSITIONS.

Programming preshot text. To program a preshot position press **PROGRAM** then **1** followed by number of the preshot. EG to program preshot 1 press **PROGRAM 1 1**. To program preshot 2 press **PROGRAM 1 2**. To program preset 14 press **PROGRAM 1 14**. After the preshot has been programmed the interface issues an AUX 62 to display the preshot text menu. The same keystrokes are used to program preshot text as when programming zone titles.

USING A TX400DC TO ACCESS THE ADVANCED FEATURES

Menu Access:

Press and HOLD # and tap 1 TWICE will display the dome's menu

Use the joystick to navigate the cursor. **FOCUS FAR** or **FOCUS NEAR** can be pressed to enter the next menu item or to return press either **IRIS OPEN** or **IRIS CLOSE**. When completely out of the menu issue a goto preset command to put the Rx100 into normal mode. Press **1** will move to preshot 1.

Program Zone Title:

Press and HOLD # and tap 2 will allow the title for the current zone to be programmed.

Use the joystick as described on screen. Use the following keystrokes to program the text:

FOCUS NEAR – Select a current character, **FOCUS FAR** – Clear character, **IRIS CLOSE** – Backspace and **IRIS OPEN** – Return

Record Autoplay:

Press and HOLD # and tap 3 allow autoplay 'A' to be recorded.

Press **FOCUS FAR** or **FOCUS NEAR** to start the recording or **IRIS CLOSE** to abandon recording. Once recording has started, use the joystick and focus keys as required. To end the recording, press and **HOLD #** and tap **3**. The recording can be replayed continuously by pressing the **AUTOPAN** key.

Reset dome defaults: USE WITH EXTREME CARE AS ALL THE DOME PROGRAMMING WILL BE LOST.

Press and HOLD # and tap 4 TWICE to display the dome's software version. Repeating the key strokes for a THIRD time will issue a SET 899 to reset the dome including ALL PRESHOT POSITIONS.

Programming preshot text. To program a preshot position press and HOLD **PROGRAM** then tap the preshot required, 1 – 8. EG to program preshot 1 press and HOLD **PROGRAM** then tap **1**. To program preshot 2 press and HOLD **PROGRAM** and tap **2**. To program preset 8 press and HOLD **PROGRAM** and tap **8**. After the preshot has been programmed the Rx100 issues an AUX 62 to display the preshot text menu. The same keystrokes are used to program preshot text as when programming zone titles.

USING DM SPRITE/DSL/DS/DS2 TO ACCESS THE ADVANCED FEATURES

The DM units use a series of * commands to access the advanced features. The Digital Sprite or DS does not have a '0' key instead the '10' key is used when ever the '0' key is mentioned. Eg to access the dome menu on a System Sprite you would key *889 002 and on the Digital DS you would key in *889 10 10 2. The examples below assume control from the Digital Sprite keyboard. If a System Sprite is used then please use the '0' key whenever the '10' key is mentioned.

Menu Access:

*889 10 10 2 repeated TWICE will display the dome's menu

Use the joystick to navigate the cursor. **FOCUS FAR** or **FOCUS NEAR** can be pressed to enter the next menu item or to return use *889 10 10 3 which simulates an iris command. When completely out of the menu issue a goto preset command to put the Rx100 into normal mode. Pressing **PRESET** followed by **10 1** will goto preshot 1.

Program Zone Title:

*889 10 10 3 will allow the title for the current zone to be programmed.

Use the joystick as described on screen. Use the following keystrokes to program the text:

FOCUS NEAR – Select a current character, **FOCUS FAR** – Clear character, *889 10 10 4 – Backspace and *889 10 10 3 – Return

Record Autoplay:

*889 10 10 4 will allow autoplay A to be recorded.

Press **FOCUS FAR** or **FOCUS NEAR** to start the recording or *889 10 10 3 to abandon recording. Once recording has started, use the joystick and focus keys as required. To end the recording, press *889 10 10 4. The recording can be replayed continuously by pressing the **AUTOPAN** key.

Reset dome defaults: USE WITH EXTREME CARE AS ALL THE DOME PROGRAMMING WILL BE LOST.

*889 10 10 5 repeated TWICE to display the dome's software version. Repeating the key strokes for a THIRD time will issue a SET 899 to reset the dome including ALL PRESHOT POSITIONS.

Programming preshot text. To program a preshot position press and hold the **PRESET** button until the display asks for preset number. Use the camera keys to enter a 2 digit number from 01 – 16. Use the **10** key to represent 0. After the preshot has been programmed the Rx100 issues an AUX 62 to display the preshot text menu. The same keystrokes are used to program preshot text as when programming zone titles. EG to program preshot 2, press and hold **PRESET**, wait for the display, press **10** then **2**.

Control from DM Digital Sprite 2 systems

The new DM Digital Sprite 2 (DS2) keyboard now supports iris directly again. Therefore navigation through the menus will be easier by using the IRIS keys instead of *889 10 10 3 and *889 10 10 4.

7. Trouble shooting guide.

Symptom: No video

Possible causes:

Unit not powered or not connected to 'CAMERA' BNC on interface. - Check power and cabling.

Video out not connected to 'TELEMETRY' BNC on interface. - Check cabling.

If after following the above check list the video is still not present then remove both BNCs from the interface and connect together using a female/female barrel connector to check video path from camera to control point.

Symptom: No camera control.

Check CABLE and ERROR leds.

CABLE Flashing MAINLY ON. – Unit not 'seeing' telemetry – Check that the camera is selected and the telemetry type is set to BBV.

Next check that telemetry is present on video cable using either oscilloscope or adjust vertical hold on monitor to view frame blanking period and check for black/white band. If missing, power down/up the transmitter. Should this fail, swap video between working and non-working channels.

Earth loops can interrupt telemetry operation if sufficiently severe.

If hum bars are apparent, fit isolation transformer to coaxial cable.

CABLE Flashing EQUAL ON to OFF – Unit is 'seeing' telemetry ok. Check wiring between unit and dome.

J3/C1 to RXD, J3/GND to GND. Check the dome's address, 0000 or 0001, and baud rate switch, 9600.

CABLE ON or OFF permanently – Power cycle the unit and if no change then call BBV for assistance.

If the problem persists having followed the above steps, technical assistance can be received from Building Block Video. Tel: +44 (0)1323 444600

Version history:

V1 Original version.

V2 July 2002 Added documentation for 230Vac or 24Vac supply operation.

V2.1 May 2003 Software version updated to 10

Changed * command from *888 10 10 4 to *889 10 10 4 Autoplay record end in the DM Section.