



# Installation Guide



Model Shown: TX1000/16/A/DC



**Building Block Video Ltd**  
17 Apex Park  
Diplocks Industrial Estate  
Hailsham, East Sussex, BN27 3JU, UK  
Tel: + 44 (0) 1323 842727  
Fax: + 44 (0) 1323 842728  
Support: + 44 (0) 1323 444600  
[www.bbvctv.com](http://www.bbvctv.com)

## Contents

Important – Before you install	3
TX1000 Telemetry Transmitter – an Introduction	4
Unpacking	5
A simple TX1000 system	6
Technical Specification	7
Layout of the TX1000 keypad	8
Installing the TX1000 matrix & keypad	8
Status LEDs	9
Siting the keypad remotely from the base unit	9
Cable Connections	9
Keypad power requirements	9
Priority control between 2 keypad systems	9
Text display on screen	9
Camera selection	10
Monitor selection	10
Activating the sequence	10
Programming the sequence	10
Setting the sequence delay	10 - 11
Triangle key	11
Keypad functions	12
Auxiliary function switches	12
Self test	13
Iris level program	13
Maximum camera number	14
Presets	14
Patrol settings	15 - 16
Spare outputs – control of special receiver functions	16
RS422 telemetry	17
TX1000 alarm input option	18 – 20
<b>Appendix</b>	
Useful keystrokes	i
TX1000 Alarm program table	ii

# IMPORTANT

## **Before you install:**

Please read the following points before servicing or installing.

**Pre-installation checks** - It is recommended that the unit be bench tested prior to installation on the site.

**Safety during installation or servicing** - Particular care should be taken to isolate the pan/tilt head in order to prevent operation while engineering work is being carried out. In addition any ladder or other means of working on the receiver MUST NOT rest on the pan/tilt head as it is possible for the head to move when not expected.

**Safety check** - Upon completion of any service or repairs to the unit, safety checks should be performed to ensure that the unit is in proper operating condition.

**Coax grounding** - If an outside cable system is connected to the unit, be sure the cable system is grounded.

**Adhere to safety standards** - All normal safety precautions as laid down by British Standards and the Health and Safety at Work Act should be observed.

**WARNING** - TO PREVENT DANGER OF FIRE OR SHOCK, DO NOT EXPOSE THE INTERNAL COMPONENTS OF THIS EQUIPMENT TO RAIN OR MOISTURE.

**Damage requiring service** - Servicing by qualified personnel should be carried out under the following conditions:

- (a) When the power supply cord or plug is damaged;
- (b) If liquid has been spilled, or objects have fallen into the unit;
- (c) If the unit does not operate normally by following the operating instructions;
- (d) If the unit has been dropped or the enclosure is damaged

**Replacement parts** - If replacement parts are required, ensure that only replacement parts recommended by the product manufacturer are used.

## TX1000 Telemetry Transmitter – Introduction

The TX1000 is a simple to use telemetry transmitter for multi-camera CCTV systems. They are easily installed into either a new or an existing system.

Up-the-coax telemetry allows upgrading of static cameras to PTZ without the need for additional cabling. BBV RS422 telemetry is available as standard where up-the-coax telemetry is not suitable or not required. An optional 20mA twisted pair unit (TX/MK2/TPO) can be retro-fitted to the TX1000 for complete compatibility with existing TX1000 sites.

The system is available in 12 variants:

Part Number	Description
TX1000/8	Telemetry transmitter for 8 cameras with 2 monitor outputs
TX1000/8A	Telemetry transmitter for 8 cameras with 2 monitor outputs, 16 alarm input card
TX1000/8/DC	Telemetry transmitter for 8 cameras with 2 monitor outputs, with joystick Keypad
TX1000/8A/DC	Telemetry transmitter for 8 cameras with 2 monitor outputs, 16 alarm input card and joystick Keypad
TX1000/8/MU	Telemetry transmitter for 8 cameras with 2 monitor outputs, no Keypad
TX1000/8A/MU	Telemetry transmitter for 8 cameras with 2 monitor outputs, 16 alarm input card, and no Keypad
TX1000/16	Telemetry transmitter for 16 cameras with 2 monitor outputs
TX1000/16A	Telemetry transmitter for 16 cameras with 2 monitor outputs, 16 alarm input card
TX1000/16/DC	Telemetry transmitter for 16 cameras with 2 monitor outputs, with joystick Keypad
TX1000/16A/DC	Telemetry transmitter for 16 cameras with 2 monitor outputs, 16 alarm input card and joystick Keypad
TX1000/16/MU	Telemetry transmitter for 16 cameras with 2 monitor outputs, no Keypad
TX1000/16A/MU	Telemetry transmitter for 16 cameras with 2 monitor outputs, 16 alarm input card, and no Keypad

All variants allow the use of two fully independent keypads.

The transmitter is a two part design: the base unit, which is wall or rack mounting; and the keypad which is connected by a video cable and a bi-directional RS232 link running at 9600 baud, No parity, 8 data bits and 1 stop bit.

## Unpacking

Inspect the packaging for signs of damage. If damage has occurred, advise the carriers and/or the suppliers immediately. Unpack the transmitter carefully and check all the items are included:

Part Number	Description	TX1000 main unit	Keypad	2 x mounting brackets	4 x M4 screws	PSU	Manual	Warranty card
TX1000/8	Telemetry transmitter for 8 cameras with 2 monitor outputs	X	X	X	X	X	X	X
TX1000/8A	Telemetry transmitter for 8 cameras with 2 monitor outputs, 16 alarm input card	X	X	X	X	X	X	X
TX1000/8/DC	Telemetry transmitter for 8 cameras with 2 monitor outputs, with joystick KBD	X	X	X	X	X	X	X
TX1000/8A/DC	Telemetry transmitter for 8 cameras with 2 monitor outputs, 16 alarm input card and joystick KBD	X	X	X	X	X	X	X
TX1000/8/MU	Telemetry transmitter for 8 cameras with 2 monitor outputs, no KBD	X		X	X	X	X	X
TX1000/8A/MU	Telemetry transmitter for 8 cameras with 2 monitor outputs, 16 alarm input card, and no KBD	X		X	X	X	X	X
TX1000/16	Telemetry transmitter for 16 cameras with 2 monitor outputs	X	X	X	X	X	X	X
TX1000/16A	Telemetry transmitter for 16 cameras with 2 monitor outputs, 16 alarm input card	X	X	X	X	X	X	X
TX1000/16/DC	Telemetry transmitter for 16 cameras with 2 monitor outputs, with joystick KBD	X	X	X	X	X	X	X
TX1000/16A/DC	Telemetry transmitter for 16 cameras with 2 monitor outputs, 16 alarm input card and joystick KBD	X	X	X	X	X	X	X
TX1000/16/MU	Telemetry transmitter for 16 cameras with 2 monitor outputs, no KBD	X		X	X	X	X	X
TX1000/16A/MU	Telemetry transmitter for 16 cameras with 2 monitor outputs, 16 alarm input card, and no KBD	X		X	X	X	X	X

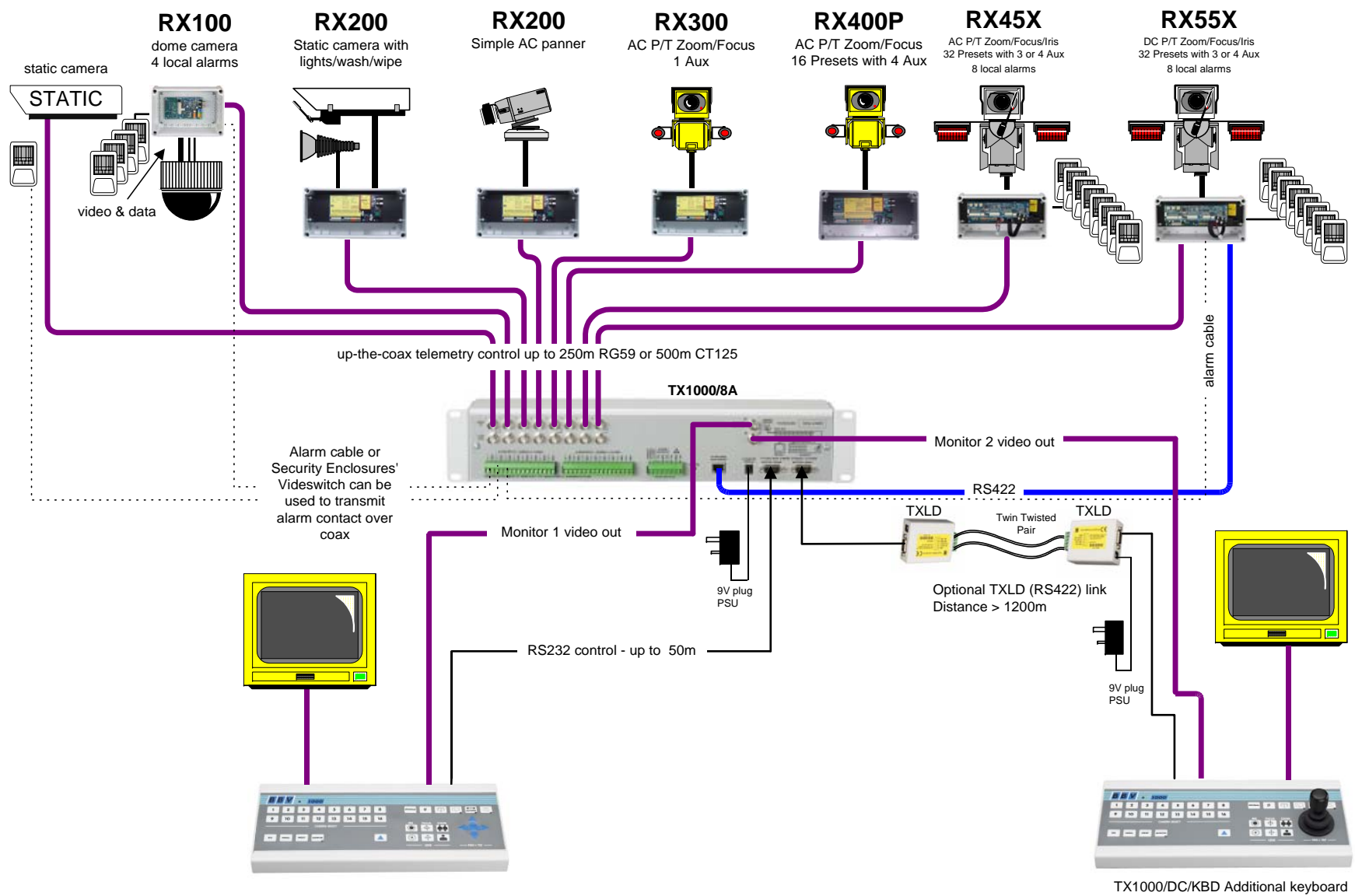

A Simple TX1000 System

## Technical Specification

Power supply	9V dc 500mA			
Inputs	Data input to base unit is RS232 via 9-pin D connector RS232 port allowing remote control from PC (9600, N, 8, 1)			
Outputs	BBV up the coax BBV RS422 20mA option (order the TX/MK2/TPO)			
Features	2 keypads supported 2 monitor outputs 8 – 16 camera inputs Optional alarm input Up-the-coax & RS422 telemetry supported Can be powered off 12V vehicle supply			
Installation	Base unit is 2U 19in rack mountable metalwork or wall mounted via the fixing brackets supplied			
Dimensions	Width	Depth	Height	Weight
TX1000/KBD	427mm	45mm	180mm	3 kg
TX1000/KBD/DC	427mm	115mm	180mm	3 kg
Base Units:				
TX1000/8	427mm	55mm	90mm	4 kg
TX1000/8A	427mm	55mm	90mm	4 kg
TX1000/16	427mm	55mm	90mm	4 kg
TX1000/16A	427mm	55mm	90mm	4 kg

## Layout of the TX1000 keypad



### Installing the TX1000 Matrix & Keypad

1. Mount the base unit on the wall or in a rack.
2. Connect the keypad to 9 pin D connector to the relevant keypad socket on the Matrix:  
  
    Monitor 1 – Keypad 1  
    Monitor 2 – Keypad 2
3. Connect a BNC cable from output M1 to the keypad, and connect the other keypad BNC to the video monitor's video input. Make sure that the monitor is terminated, not Hi-Z.
4. If the keypad is remotely sited from the base unit, connect the 9Vdc plug mounted power supply to the keypad via the 2.1mm power connector.
5. Connect either a second video monitor, or the second keypad to Output 2. Note that even if both keypads are local to the main unit, the second keypad must be powered from its own 9Vdc power supply.
6. Connect the BNC cables from the cameras/receivers to the upper BNC sockets in each row, marked "VIDEO IN".
7. Connect any other equipment requiring the camera video signals to the lower BNC sockets marked "LOOP OUT". Note that the action of connecting to the video out socket removes the 75Ω termination.
8. If the user relay terminals are being used, connect these to the LOW VOLTAGE equipment of your choice.

PIN 6	Normally closed
PIN 7	Common
PIN 8	Normally open

9. Plug in the Matrix 9Vdc power supply.

## Status LED

The STATUS LED should flash and the monitors should show the video from Camera 1 on power up. If the LED is permanently ON or OFF, the unit is in a fault condition. Please contact BBV technical support on: 01323 444600.

## Siting the keypad remotely from the base unit

The keypad uses RS232 9600 baud, no parity, 1 stop bit to communicate with the TX1000 Matrix. The keypad is full duplex will function normally up to 50m from the Matrix. Beyond this distance, any of the proprietary cable extenders may be used (e.g. modems, fibre optics, infra red/microwave links) without any difficulty.

## Cable Connections

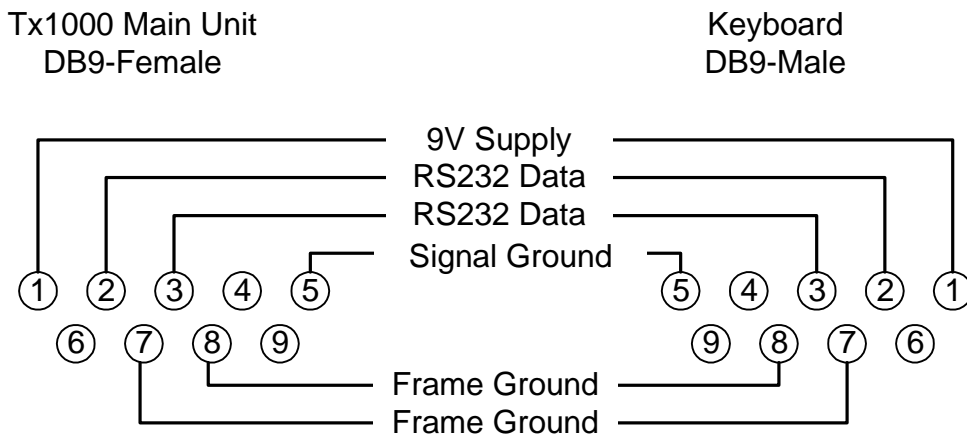

## Keypad power requirements

Fully isolated 9 – 12V ac/dc power supply. The maximum current draw is 150mA.

## Priority control between two keypad systems

Keypad one has priority over keypad two. If keypad one is only viewing but not operating any camera, then keypad two may move that same camera. After movement commands on keypad one, there is a 20 second lock out period before control is given to keypad two.

## Text display on screen

### Monitor 1:

Connect a coax cable from the M1 output on the matrix to the keypad, and connect the keypad to the monitor's video output using the other BNC on the keypad.

### Monitor 2:

With one keypad - Connect as above, then connect a coax link from Monitor 1 to Monitor 2. This duplicates the text onto both screens.

With two keypads – Connect a coax cable from the M2 output on the matrix to the keypad, and connect the keypad to the monitor's video output using the other BNC on the keypad.

### Camera Selection

A camera may be selected onto the controlled monitor by pressing the relevant numbered camera key:

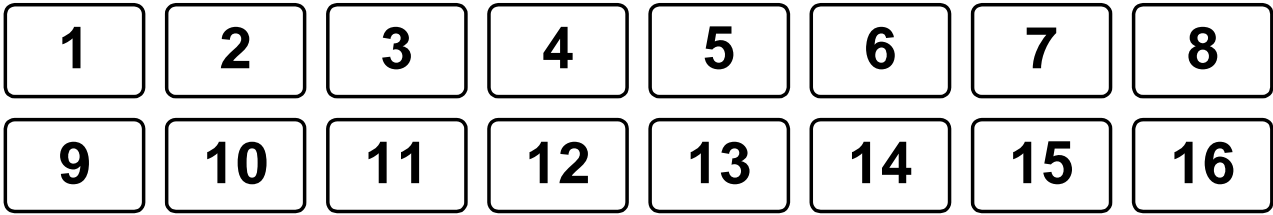

### Monitor Selection

The monitor key has a red LED, which is lit when the keypad is controlling the second monitor output.



Pressing the monitor key toggles between monitor 1 and monitor 2.

### Activating the Sequence

Pressing the sequence key will start the camera sequence on the monitor that is currently selected.



The on screen display changes from CAM XX to SEQ XX to indicate that the sequence is running. To stop the sequence, select a camera on the monitor.

### Programming the Sequence

Holding down the sequence key causes the sequence to run through the list of cameras at the rate of one per second, allowing the operator to quickly determine which cameras are being sequenced. All cameras are included by default.

To add/remove a camera from the Sequence, hold the Sequence key and press the relevant camera key. This will add/remove the camera from the Sequence.

### Setting the Sequence delay

Determine the delay you wish to set from the table below:

Key number	Time delay (seconds)	Key number	Time delay (seconds)
1	5	9	45
2	10	10	50
3	15	11	55
4	20	12	60
5	25	13	65
6	30	14	70
7	35	15	75
8	40	16	80

Press the Program key to enter the menu and select '9'. The on screen prompt "Seq Delay" appears, inviting the operator to enter a number from the table above for the time delay.



**Menu  
Option**

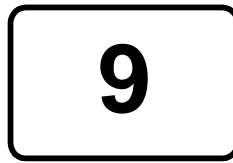

**And**

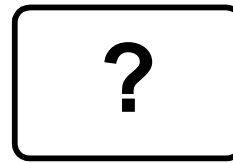

**Delay number**

After entering the delay value, the screen clears.

### **Triangle key**

This key activates a relay in the base unit:

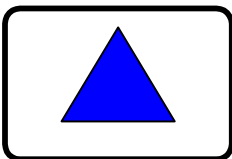

Pressing the key causes triangle relay contacts to changeover; releasing the key causes the contacts to revert to original position. This relay may be used by the installer to activate a panic record facility on a VCR, or to activate a video printer, etc. These contacts are low voltage, low current only.

**DO NOT CONNECT THESE CONTACTS TO MAINS POTENTIALS.**

**USE LOW VOLTAGE ONLY.**



## Keypad functions

The keypads should not be connected or disconnected from a "live" working unit, as this may damage the RS232 components.

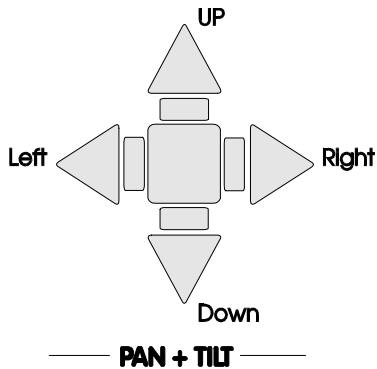

### Pan and Tilt Action:

Press the relevant direction arrow

### IRIS

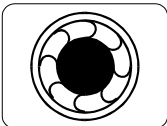

### FOCUS

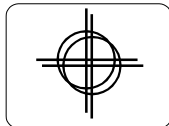

### ZOOM

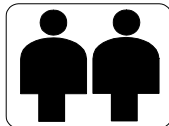

### Lens Action

There are six lens function switches on the TX1000 keypad. These are:

- Iris Open
- Iris Close
- Focus Near
- Focus Far
- Zoom In
- Zoom Out

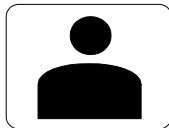
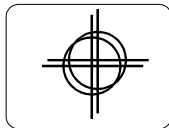
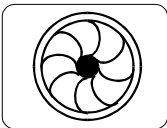

### LENS

Press and hold the relevant key until the desired picture is obtained.

**Note:** If the key is pressed and held for longer than one second, High Speed Lens Action is activated. Inching is achieved by repeated quick presses of the key.

### Auxiliary function switches

There are four auxiliary function switches on the TX1000 keypad:



Wash – Press and hold for washer motor to run

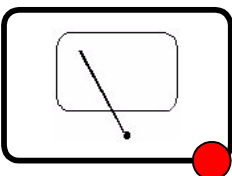

Wipe - Latching output, press on/press off

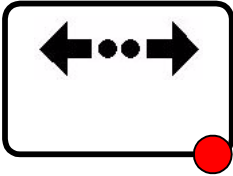

Autopan - Press, LED lights up and autopan motor starts. Pressing Left or Right stops Autopan

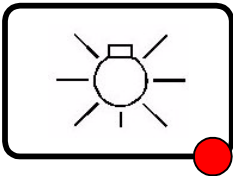

Lights - Latching output, press on/press off

### Self Test

To activate the self test feature for any particular camera receiver, first select that receiver, then press the 'Program' button and select 'Menu Option 2'.

The screen text will clear and Self Test will be activated. See the RX Series Telemetry Receiver Installation Handbook for more details.



And  
option

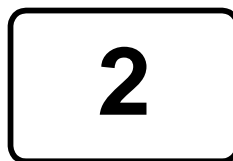

### Iris Level Program

To preset the aperture of the iris, press 'Iris Open' or 'Iris Close' until the desired level is reached, then press 'Program' and 'Option 3'.



And  
option

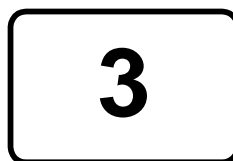

**Note:** After adjustment, there is a 15 second period, in which to program the iris setting. After this, the iris reverts to its default setting.

### Maximum Camera Number

To set the Maximum camera number, Press Program, then enter 15 followed by the maximum number of cameras connected to the system

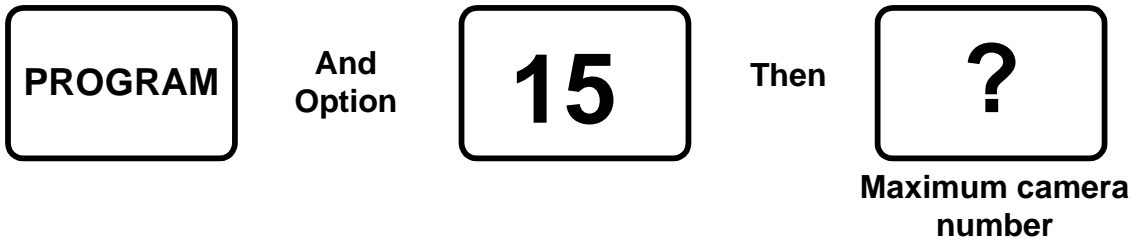

Setting the maximum camera number will prevent the TX1000 from patrolling through unused cameras on a patrol.

**The remainder of this manual refers to features found only on receivers that support presets: RX100, RX400P, RX45X, RX55X**

### Presets

To select a programmed preset, press the Preset key. On the screen, 'Preset' will appear. While holding down the Preset key, press the required preset number.



To programme a preset, first position the camera using the Up/Down and Left/Right arrows. Then set Zoom and Focus. When satisfied with the position and the quality of the picture, press Program and select Option 1. When the on screen display changes to "Program Preset", enter the number of the preset you wish to program.

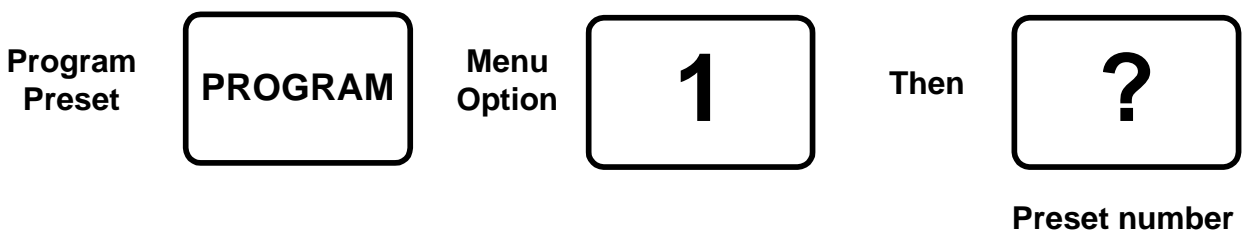

To erase a preset, press the Program key to gain access to the menu. Select Option 4 and when the display changes to "Erase Preset", select the number of the preset to be erased.



## Patrol settings

There are two preset patrols that can be started by the TX1000.

To activate: Press and hold the Patrol key and either Key 1 or Key 2. All other keys are ignored. Their function is to enable a string of presets to be selected in turn, switching between presets after a fixed period of time (default 30 seconds).

These patrols can be stopped at any time by pressing any of the four arrows on the Pan and Tilt control or moving the joystick, when the receiver on which patrol is running is selected.

### To Programme a Patrol

There is no separate patrol-programming function with the BBV TX1000 keypad. Once a preset has been programmed, it is automatically included in Patrols 1 and 2.

### To Remove a Preset from a Patrol

1. Select the receiver on which the patrol is to run.
2. Press Program to gain access to the menu, then press 5 to remove a preset from Patrol 1 or 6 to remove from Patrol 2, followed by the preset number to be removed.

To Remove a Preset from Patrol 1:

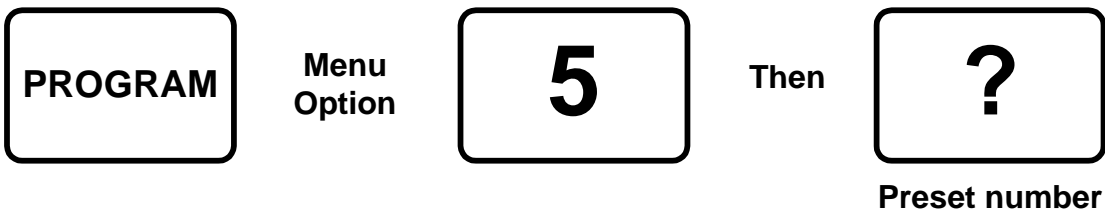

To Remove a Preset from Patrol 2:

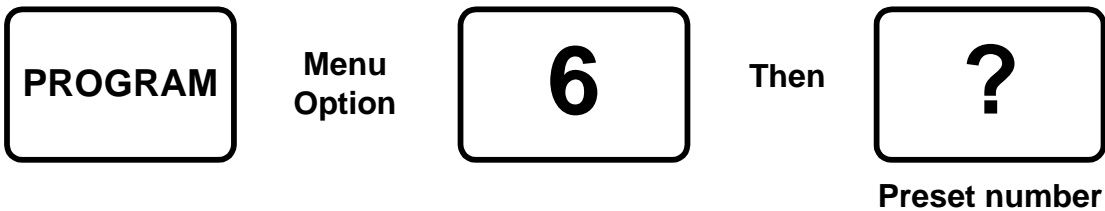

### To Programme a Time Period for a Patrol

First, determine the time delay required from the table below:

Key Number	Time delay (seconds)	Key Number	Time delay (seconds)
1	Random 0 to 100 seconds	9	96
2	12	10	108
3	24	11	120
4	36	12	132
5	48	13	144
6	60	14	156
7	72	15	168
8	84	16	180

**Setting a delay for Patrol 1:**

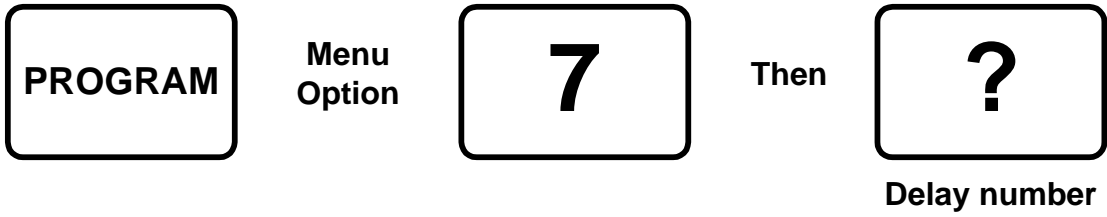

**Setting a delay for Patrol 2:**

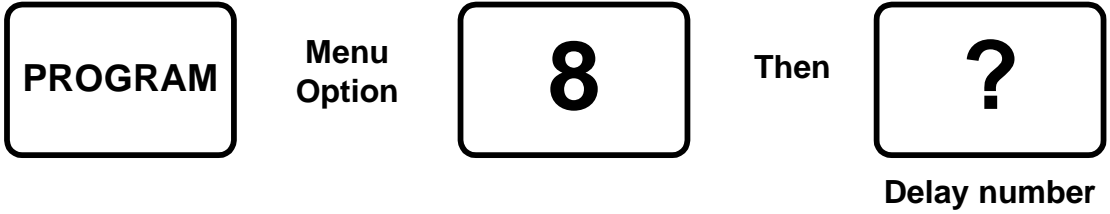

**Spare outputs – Control of special receiver functions**

Four additional spare functions are provided which are used to carry out advanced programming depending on the type of receiver and/or dome used. Please refer to the receiver's manual for details.

The additional functions are activated by pressing the # key and one of the auxiliary keys simultaneously. An on screen display confirms which output has been activated.

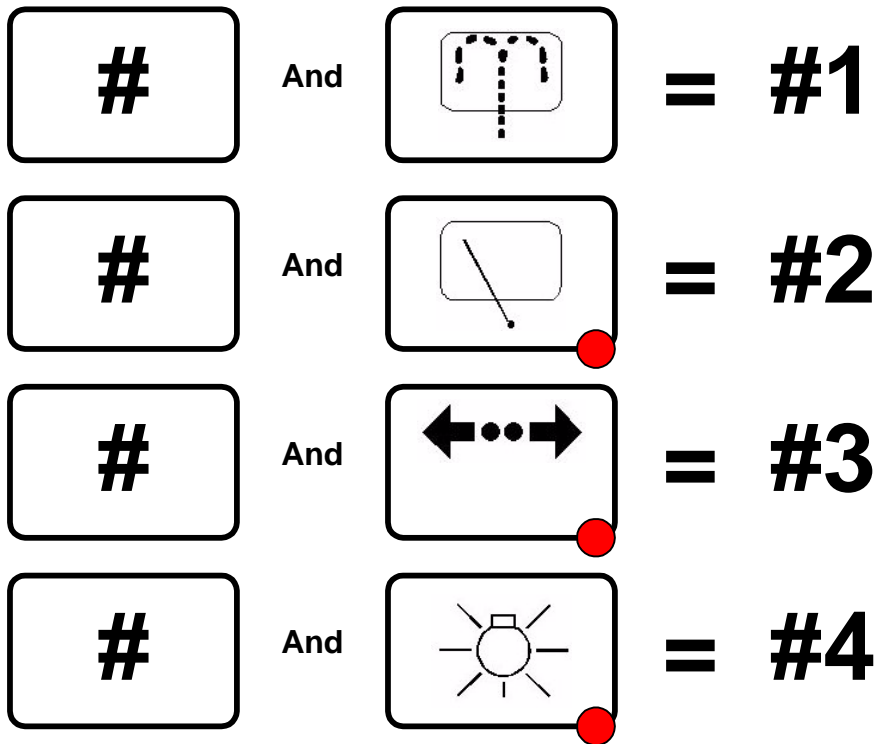

# RS422 TELEMETRY

The TX1000 matrix has a single RJ45 connector that is used to control BBV RS422 telemetry receivers or a range of 3<sup>rd</sup> party receivers and dome cameras via a STARCARD/CONVERTER. It is recommended that a RJ45 breakout box and CAT5 patch cable are used to connect the telemetry connector.

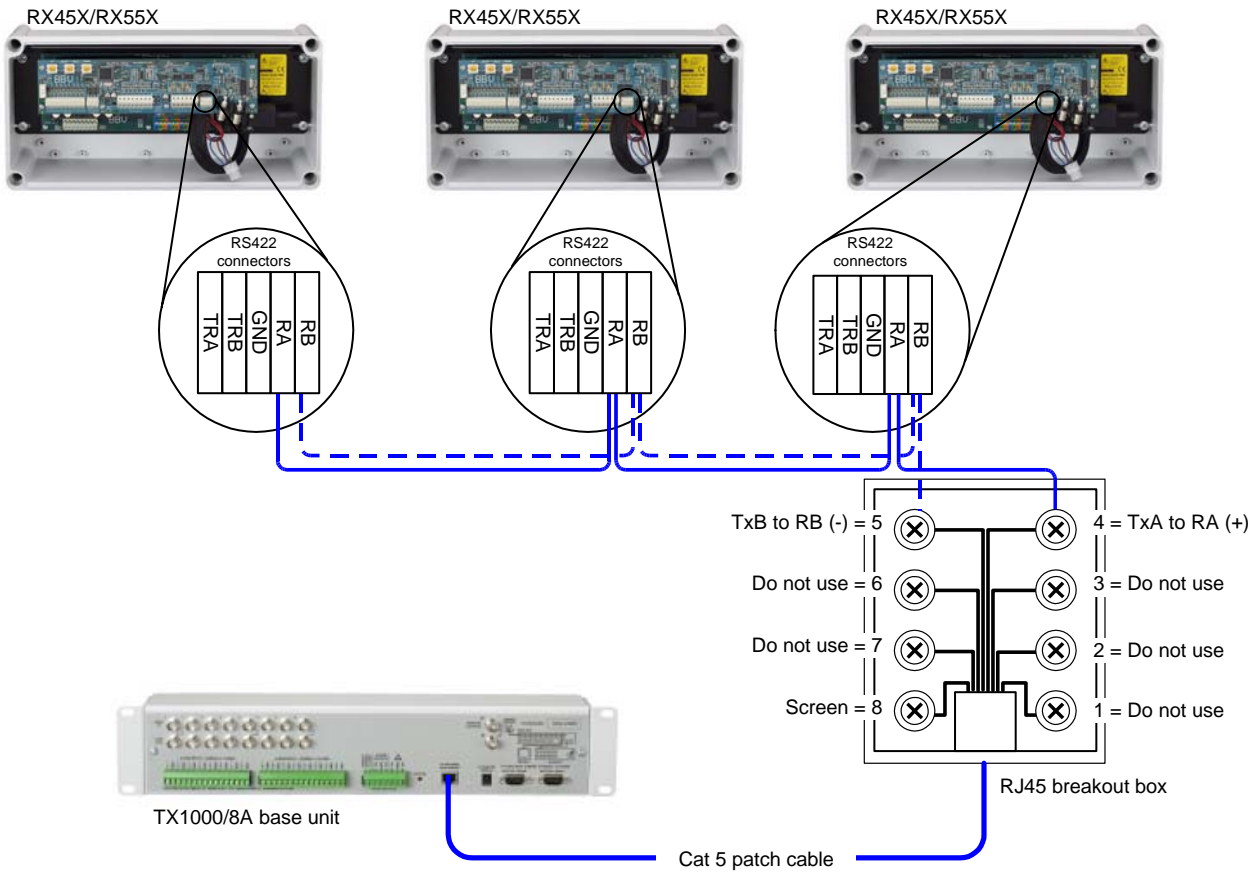

When daisy chaining the RS422 telemetry ensure that the end of line receiver has RS422 terminated and intermediate receivers are not terminated.

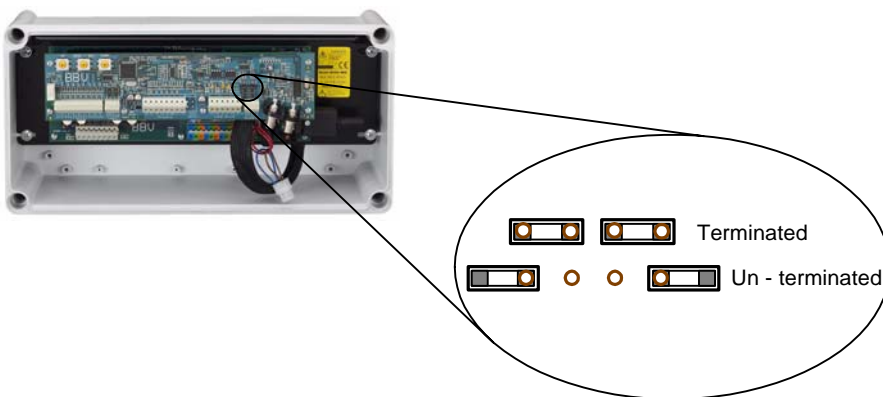

If the system is to be star wired then a BBV STARCARD can be used which provides 8 individual RS422 outputs.

A STARCARD/CONVERTER can be used to allow control of a range of 3<sup>rd</sup> party domes and telemetry receivers with 8 x RS422 outputs.

## TX1000 Series Alarm Input Option

### Alarm Inputs

Alarms activate on opening of contacts. Connect each alarm pair to a volt free contact.

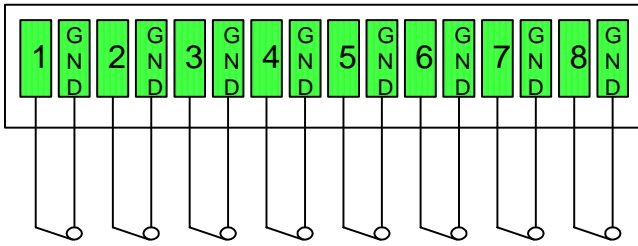

Normally closed inputs, opening for alarm

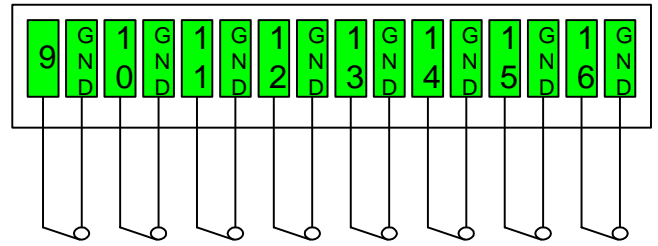

Each input has 56K internal pull up to 9Vdc

### Alarm output

A set of volt free changeover contacts are provided as an output from the alarm package. The contacts change state when any alarm input has gone from closed to open. The contacts stay switched for a programmed length of time. The contacts are accessed via contacts 3, 4 & 5 on the smaller green 'RELAY CONTACTS' connector.

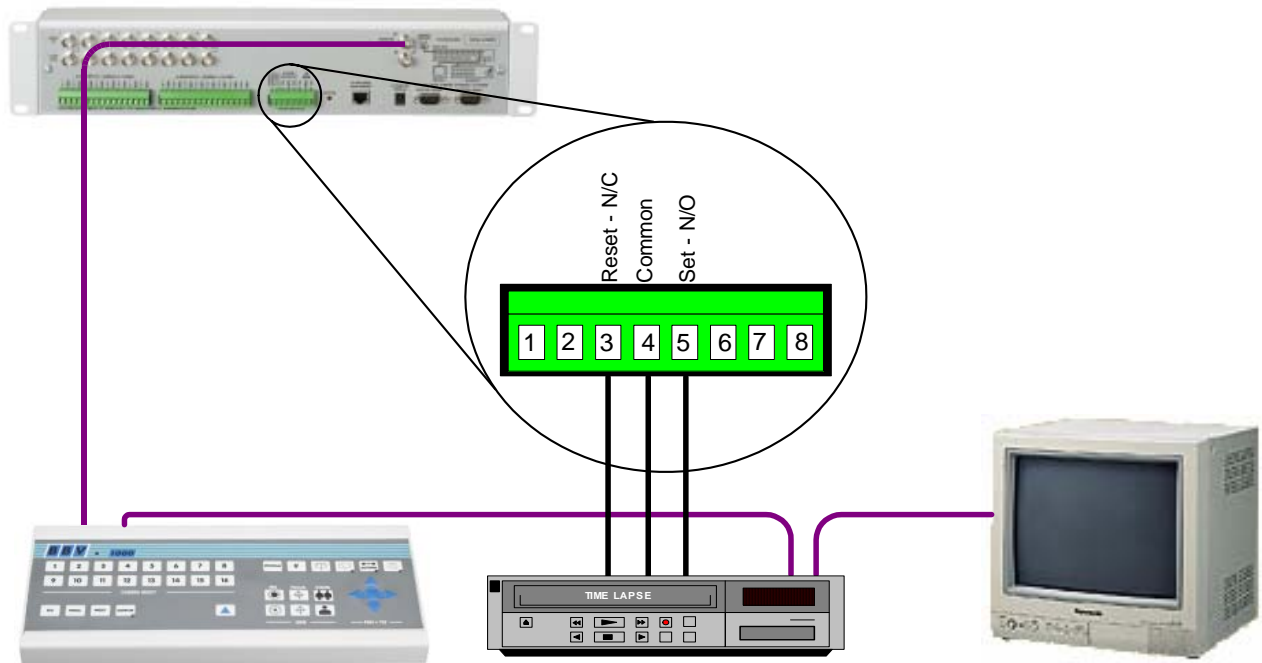

\* Linking pins 1 & 2 will disable the TX1000 alarm handling. Any receiver local alarms are not disabled.



**DO NOT CONNECT MAINS POTENTIALS TO THESE CONTACTS  
USE LOW VOLTAGE ONLY!!**

## Enabling/Disabling the Alarm package

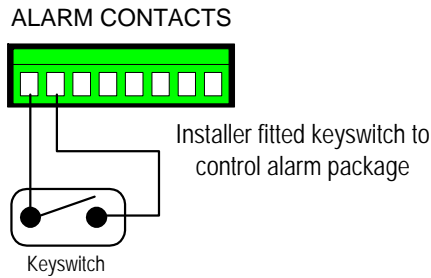

The alarm package can be enabled/disabled; for example at night when the building is empty the alarms can be enabled via a keyswitch fitted across alarm contacts pins 1 and 2.

Closed switch = alarm package disabled  
Open switch = alarm package active

Local alarms to the receiver will NOT be disabled using this link.

**Note:** Cutting the switch cable will activate the alarm package.

### Action on alarm

Each alarm can be programmed to switch monitor 1 to display a specific camera and go to a preset position for that camera. An alarm message is displayed on the screen and the alarm output relay closes for a programmed length of time.

If the sequence is running then the alarm time is added to the sequence time, and the sequence continues to run after the alarm times out.

If the sequence is not running, the alarm message and selected camera remain on monitor 1 until a manual camera selection.

The camera selected and the preset command issued is programmable via the keypad. Press the program key and select '11':



The following message then appears on screen:

Program Alarm?

Enter the alarm number you wish to program. Then the following prompt appears:

Camera?

Enter the camera number you wish to use when the alarm is triggered.

Preset?

Enter the number of the Preset you wish to go to when the alarm is triggered.

The length of time the contacts close is also programmable. To program the length of time the contacts close:

First determine the amount of time you wish the contacts to be closed:

Key number	Time (seconds)	Key number	Time (seconds)
1	5	9	45
2	10	10	50
3	15	11	55
4	20	12	60
5	25	13	65
6	30	14	70
7	35	15	75
8	40	16	80

Press the Program key to enter the menu and select '10' followed by the key number relating to the amount of time the contacts are to be closed for:

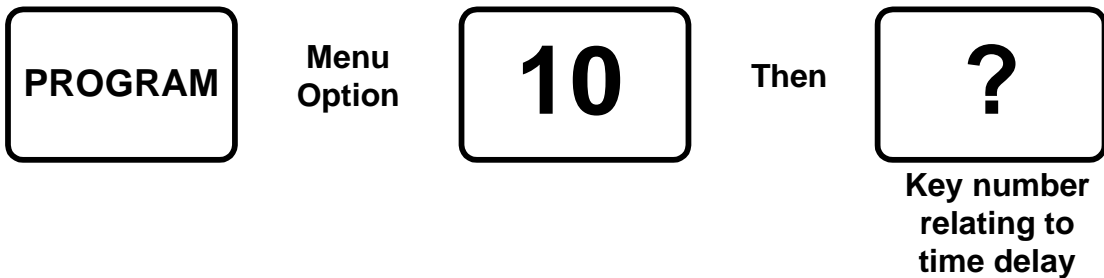

**To use the preset features you must have fitted a receiver that supports preset positioning; RX400P, RX45X, RX55X and preset PTZ heads or RX100 and a suitable dome camera.**

**Receivers with local alarms.**

The RX100 dome interface has 4 local alarm inputs and the RX45X and RX55X have 8 local alarm inputs. All have a single normally closed relay output that opens momentarily when a local alarm is activated. This output can be wired to an alarm input on the TX1000 or an alarm system.

A receiver local alarm will cause the relevant preset position to be automatically selected without the intervention of a telemetry transmitter (see the receiver installation guide). If the transmitter also generates a preset command, then the receiver's preset will be overridden. To overcome this during alarm programming use preset 16 which will prevent the TX1000 from sending a preset command for this particular alarm input.

The standard preset receivers can be programmed to go to a preset position 1 - 15 during an alarm.

- Blank for your notes -

## Appendix

### Useful Keystrokes:

#### Software version

Hold hash and tap the 10 key to make the software version number, number of watchdogs and number of resets appear on screen.

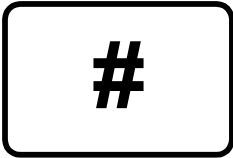

And tap

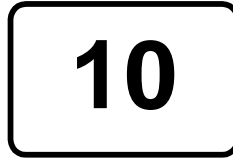

### TX1000 Alarm Program Table

Site Name	
Date	

PROGRAM	11	INPUT NUMBER	CAMERA NUMBER	PRESET
PROGRAM	11	1 to 16	1 to 8 or 1 to 16	1 to 16
PROGRAM	11	1		
PROGRAM	11	2		
PROGRAM	11	3		
PROGRAM	11	4		
PROGRAM	11	5		
PROGRAM	11	6		
PROGRAM	11	7		
PROGRAM	11	8		
PROGRAM	11	9		
PROGRAM	11	10		
PROGRAM	11	11		
PROGRAM	11	12		
PROGRAM	11	13		
PROGRAM	11	14		
PROGRAM	11	15		
PROGRAM	11	16		

## Extend your BBV Warranty from 12 months to 3 years

As of the 1<sup>st</sup> September 2008 BBV have offered our customers the opportunity to extend the standard 12 month warranty to 3 years.

You must register for the extended warranty within 12 months of the date of manufacture.

### How to register for the 3 year warranty

Registering for the new, longer 3 year warranty term is quick and easy.

Either:

Complete the warranty application card that comes in the box with your BBV product, and return it FREEPOST to BBV:





### BBV 3 Year Warranty

If this card is returned with the serial number of the product and the Installation company details BBV will extend the warranty period from 12 Months to 36 Months.

Number of Units,  Start Serial No.  Final Serial No.

Contact Name: \_\_\_\_\_  
Company Name: \_\_\_\_\_  
Phone Number: \_\_\_\_\_  
Site Name: \_\_\_\_\_  
Address 1: \_\_\_\_\_  
Address 2: \_\_\_\_\_  
Address 3: \_\_\_\_\_  
Post Code: \_\_\_\_\_  
e-mail address: \_\_\_\_\_

Please could you send me information especially on:  
 Rx100s  
 Rx45x & Rx55x  
 FBM Video Matrices  
 Tx1500 Video Matrices  
 Starcard & Starcard Converters  
 BBV Quad  
 Pick A Point

Do you read:    
 I do not require any other further product information.  
Please refer to [WWW.BBVCCTV.COM](http://WWW.BBVCCTV.COM) for terms, conditions & exclusions  
VAT Reg. No. 621758439 Registered in England No. 2852921 Registered office: 17 Apex Park Diplocks Way Hailsham East Sussex UK BN27 3JU

Or alternatively:

Register online at: [www.bbvctv.com](http://www.bbvctv.com)

Simply enter your details on the 'Warranty Cover' page.

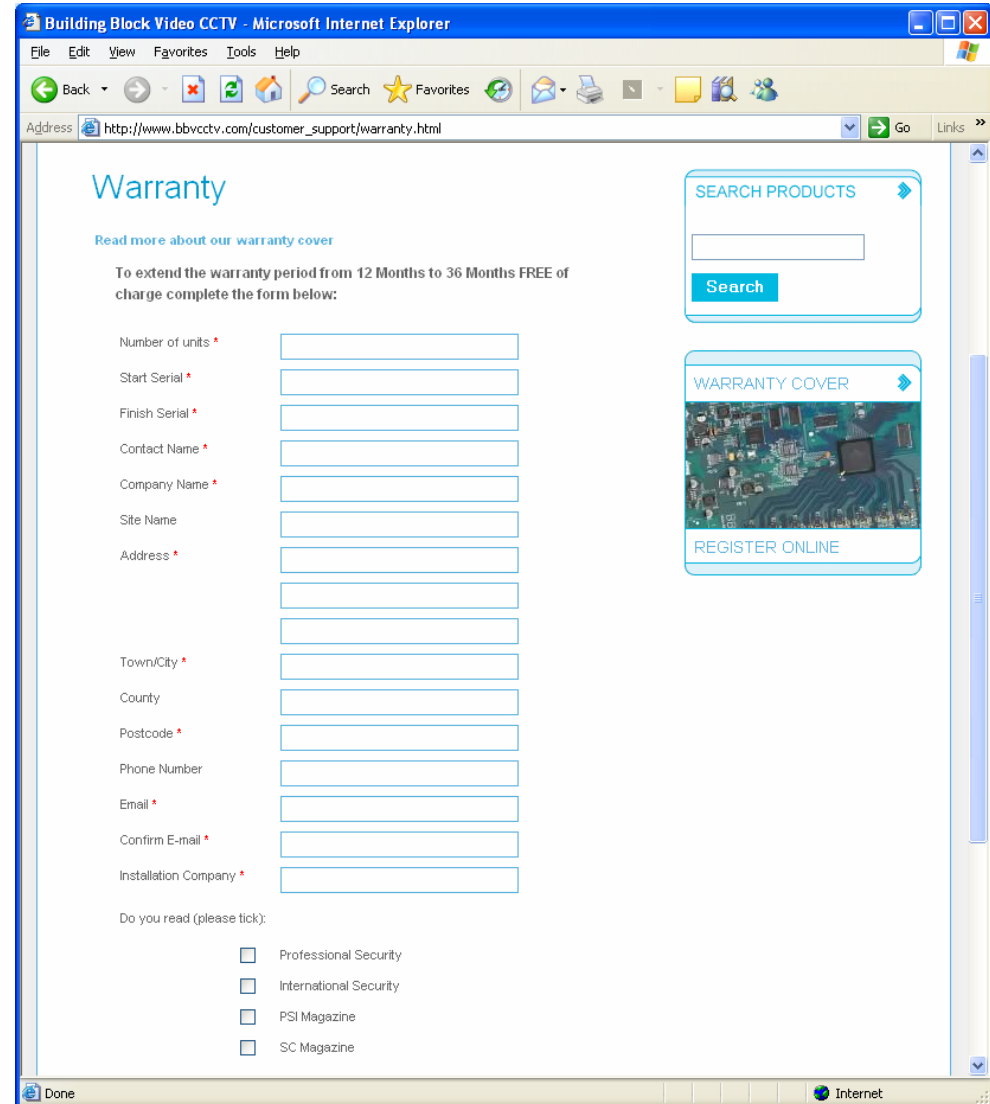

**Building Block Video Ltd**

Tel: + 44 (0) 1323 842727

Fax: + 44 (0) 1323 842728

Support: + 44 (0) 1323 444600

[www.bbvctv.com](http://www.bbvctv.com)